

CR15+ CR10+ CR5+ Operator Manual

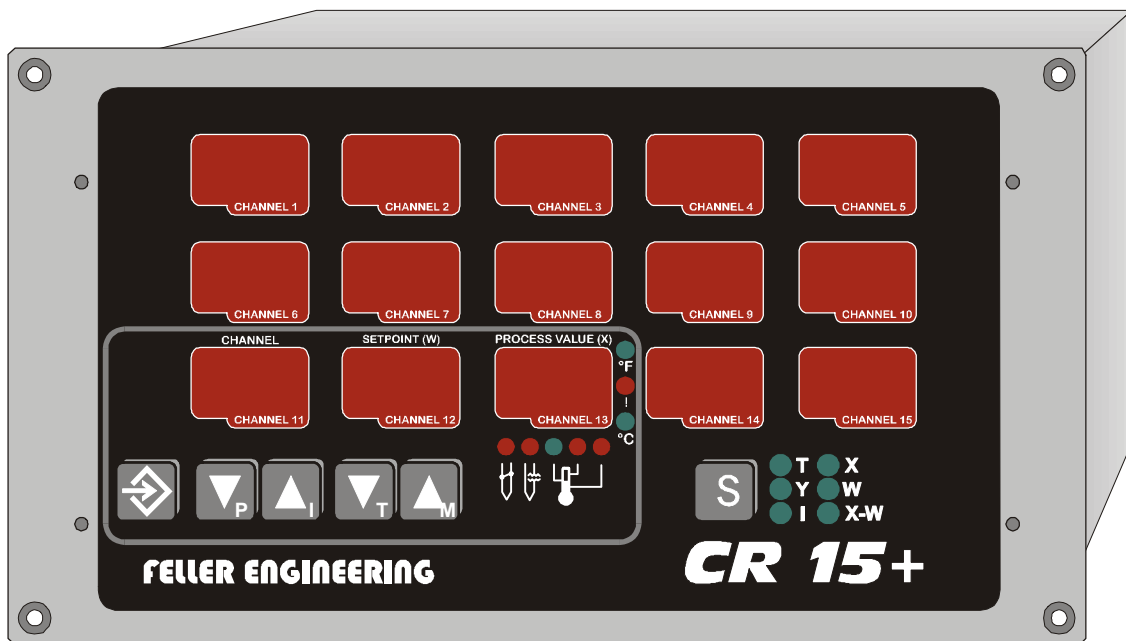

Contents

1	Introduction	5
2	Operation	6
2.1	LED-Indicators	6
2.1.1	Fahrenheit- and Celsius-LED	6
2.1.2	Watchdog-LED	6
2.1.3	Low temperature-LED	6
2.1.4	High temperature-LED	6
2.1.5	OK-LED	6
2.1.6	Broken sensor-LED	7
2.1.7	Shorted sensor-LED	7
2.1.8	Total-display-LEDs	7
2.2	Total display:	7
2.2.1	Selection	7
2.2.2	Reports	7
2.3	Setting mode:	8
2.3.1	Locking / unlocking for settings	8
2.3.2	Settings and variations	8
2.3.3	Setpoints (From level 001)	8
3	Settings for the unit	8
3.1	Selection of the operation mode	8
3.1.1	Zone OFF	9
3.1.2	Setting of fixed output rates (manual mode)	9
3.1.3	Measuring zones	9
3.2	Settings for all zones	9
3.2.1	ID-Level (From level 000)	9
3.2.2	Outputs (From level 003)	9
3.2.3	Setpoint-program (From level 002)	9
4	Setting parameters	10
4.1	Parameter mode	10
4.1.1	Selection of parameters	10
4.1.2	Leave parameter mode	10
4.2	Definition of the parameters	10
4.2.1	Parameter 1: Lo Alarm (From level 002)	10
4.2.2	Parameter 2: Hi Alarm (From level 002)	10
4.2.3	Parameter 3: Deviation Alarm (From level 002)	11
4.2.4	Parameter 4: x_p Heating (From level 002)	11
4.2.5	Parameter 5: t_i (Integral part for heating) (From level 002)	11
4.2.6	Parameter 6: t_d (Differential part for heating) (From level 002)	11
4.2.7	Parameter 7: Heating ramp (From level 002)	12
4.2.8	Parameter 8: Cycle time heating (From level 003)	12
4.2.9	Parameter 9: Maximum output rate for heating (From level 003)	12
4.2.10	Parameter 10: Diagnosis time (From level 003)	12
4.2.11	Parameter 11: Temperature drop (From level 001)	12
4.2.12	Parameter 12: Cooling medium (From level 003)	13
4.2.13	Parameter 13: Injection time for steam cooling (From level 003)	13
4.2.14	Parameter 14: x_p cooling (From level 002)	13
4.2.15	Parameter 15: t_i cooling (From level 002)	13
4.2.16	Parameter 16: t_d cooling (From level 002)	13
4.2.17	Parameter 17 Cooling ramp (From level 002)	13

4.2.18	Parameter 18: cycle time cooling (From level 003)	13
4.2.19	Parameter 19: maximum cooling rate (From level 003)	14
4.2.20	Parameter 20: Mean output rate (From level 001)	14
4.2.21	Parameter 21: Operation mode of the zone (From level 001)	14
4.2.22	Parameter 22: Preset for output rate (From level 001)	14
4.2.23	Parameter 23: Type of sensor (From level 003)	14
4.2.24	Parameter 24: Offset (From level 003)	15
4.2.25	Parameter 25: Setpoint-ramp (From level 003)	15
4.2.26	Parameter 26: Solution of the cooling rate (From level 003)	15
4.2.27	Parameter 27: Nominal current of the heater (From level 003)	15
4.2.28	Parameter 28: Range of tolerance for the current (From level 003)	15
4.2.29	Parameter 29: Scaling analogue input (From level 002)	15
4.2.30	Parameter 30: Decimal scaling (From level 002)	15
4.3	Definition of the basic parameters	16
4.3.1	Basic parameter: Alarm delay (From level 003)	16
4.3.2	Basic parameter: First zone no. (From level 001)	17
4.3.3	Basic parameter: Upper setpoint limit (HI-value) (From level 003)	17
4.3.4	Basic parameter: Celsius/Fahrenheit (From level 003)	17
4.3.5	Basic parameter: Net frequency (From level 002)	17
4.3.6	Basic parameter: Code for level 001 (From level 003)	17
4.3.7	Basic parameter: Code for level 002 (From level 003)	17
4.3.8	Basic parameter: Code for level 003 (From level 003)	17
4.3.9	Basic parameter: Bus-address (From level 003)	17
5	Further functions	18
5.1	Watchdog-function	18
5.2	Indication of internal setpoints and output rates	18
5.3	Indication of the software data	18
5.4	Self-tuning of the control-zones (From Level 002)	18
5.4.1	Self tuning of the heating by startup method	18
5.4.2	Self tuning of the cooling zone by the drop-set method	19
5.4.3	Tuning the zone by the oscillation procedure	19
5.5	Reset to the original parameters	19
6	Commissioning	20
6.1	Definition of the terminals	20
6.1.1	Sensor inputs	20
6.1.2	Power outputs (heating and cooling)	22
6.1.3	Net supply and alarm-outputs	23
6.1.4	Relay-contacts	24
6.1.5	Plug for heater-current transmitter AT083	24
6.1.6	Digital-In	24
6.2	Heater-current measuring	25
6.2.1	Start of the heater-current supervision (From level 002)	25
6.3	Plausibility check	25
6.3.1	Recognition of shorted thermocouples	25
6.3.2	Recognition of defective (shorted) actuators	26
7	Technical data and dimensions	27
8	Special extensions	29
9	Equipment	29
9.1	Current measuring via AT083 , AT064 and AU026	29

10	Serial interface	29
10.1	RS485 (default)	29
10.2	RS232	30
10.3	RS422	30
10.4	20mA Current loop	30
11	Declaration of EC-Conformity	31

1 Introduction

The microprocessor controller series **CR+** is fitted to 5, 10 or 15 temperature control loops according to the designation of the unit. It owns electrically isolated outputs (triac or transistor) as well as inputs, alternatively for thermocouples (FeCuNi or NiCrNi) or Pt100-resistors.

The outputs are switched on / off at the moment of zero-voltage. The design of three groups enables the separation of three phases at **CR15+**. The outputs are protected by 3 super fast fuses of 6A. The power supply is protected by a fuse of 0,5A..

Settings for setpoints or parameters are saved even after turn off the power supply. The internal memory stores for more than 10 years.

Four different setpoint programs may be stored at the **CR15+** and activated if necessary.

All control loops may get supervised independently for high and low alarms. A collective output relays is switched with the referring alarm. The dry contacts of the relays are available.

In case of a broken or missing sensor the controller may operate the referring zone in the manual power mode with fixed settings for the output rate.

The controller operates in the DDC (direct digital control) mode according to the PID structure with a start up routine. The P, I, D parameters for the control loops may be set.

The integrated total display shows the process values for all zones.

The controller is fit with a self-tune-mode for all zones separately. This may be activated to find new P, I, D parameters, if necessary.

The heaters may be supervised by the currents, if the required equipment is wired.

2 Operation

Front view of **CR15+**

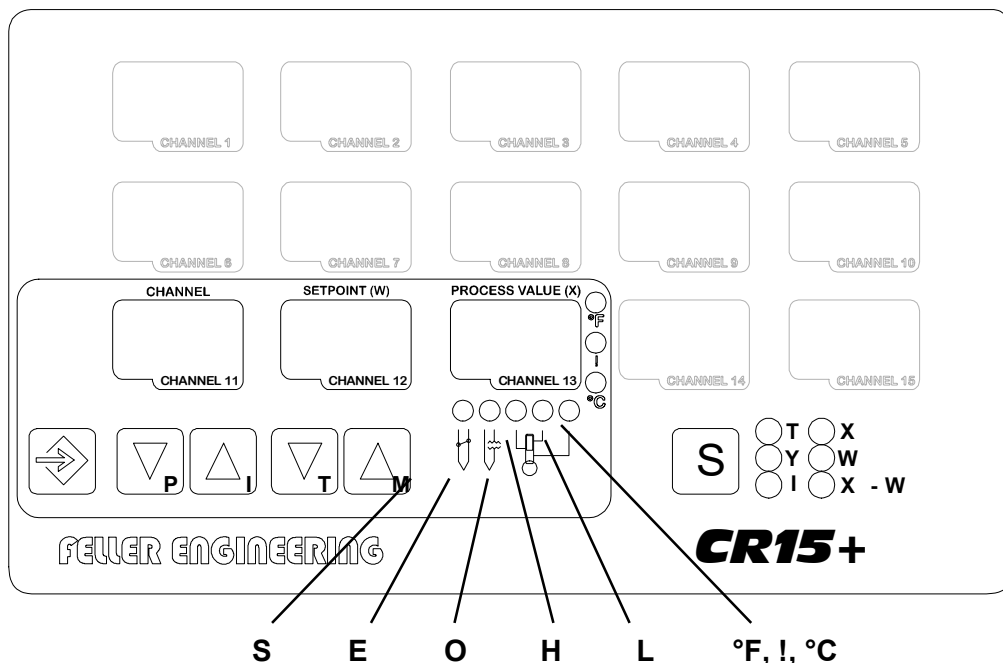

2.1 LED-Indicators

The **CR15+** indicates the status via eight different LEDs. These are summary indications. The referring functions are described in the following.

2.1.1 Fahrenheit- and Celsius-LED

The LEDs „°C“ and „°F“ inform about the unit of temperature values. The mode is selected by the basic parameters.

The display is not sized for temperature values °F > 999 degrees. So the first sign will be marked with a decimal point in front, to indicate more than 1000°F (e.g. **.230** = 1230°F).

2.1.2 Watchdog-LED

The watchdog LED „!“ is located between °C and °F. It lights in the following cases:

- problems at the power supply
- the self supervision detects defective components or
- the digital input (option) disables the outputs.

The dry NO-contact 33-34 at the rear side of the unit will get opened. A wired relay may disconnect heating and cooling from the net supply via main relay.

2.1.3 Low temperature-LED

The LED „L“ lights in case of decreasing the Lo-alarm (parameter 1) at one or more zones. The alarm-relay switches.

2.1.4 High temperature-LED

The LED „H“ lights in case of increasing the Hi-alarm (parameter 2) at one or more zones. The relay 1 switches

2.1.5 OK-LED

The green LED „O“ lights when all activated zones are within the Lo-, Hi-, or deviation-alarms (parameters 1, 2, 3). This LED flashes if all outputs are switched off (basic parameter 2).

2.1.6 Broken sensor-LED

The LED „E“ lights, if a broken sensor occurs at one or more zones or if a zone without sensor will be activated on (power mode).

The outputs of the referring zone will get switched off. The alarm relay switches.

2.1.7 Shorted sensor-LED

The LED „S“ lights, if a Pt100 sensor is shorted or the thermocouple wiring is mixed at one or more zones.

The outputs of the referring zone will get switched off. The alarm relay switches.

2.1.8 Total-display-LEDs

These LEDs beside the  key indicate the actual display mode. The active LEDs are flashing, when all outputs are switched off (basic parameter 2).

2.2 Total display:

2.2.1 Selection

The total display may be reached by:

- start of the unit
- no key operation during 120sec or
- selection by the  key.

The selection by the  key indicates all actual values „T X“, setpoints „T W“, temperature deviations „T X-W“ or the actual regulation rate „Y X“. In case of heater current supervision the actual heater currents „I X“, setpoints „I W“ or deviations „I X-W“ may be indicated.

2.2.2 Reports

The following reports may alternate with the selection „T X“ or „I X“.

-L-	Lo-alarm at this zone = low temperature
-H-	Hi-alarm at this zone = high temperature
-dL	low deviation alarm at this zone
-dH	high deviation alarm at this zone
-E-	broken sensor at this zone
-S-	shorted sensor at this zone, plausibility check
-t-	self tuning
t-E	self tuning cancelled
SSr	defective power relay(Solid State Relay) at this zone
	Indication at all zones has detected an uncontrolled current.
-I-	heater current deviation alarm at this zone

The following reports may alternate with the selection „T W“.

-P-	
OFF	Zone switched off.

The following reports may alternate with the selection „T X-W“.

-P-	Zone in power mode.
-----	---------------------

The following reports may alternate with the selection „I W“.

OFF	Zone switched off.
-----	--------------------

A dark display indicates a disabled zone (switched off).

2.3 Setting mode:

With short operation of one of the keys **P** **I** **T** **M** the display changes to the single indication. Only the 3 displays in the frame are active in this mode.

Example:

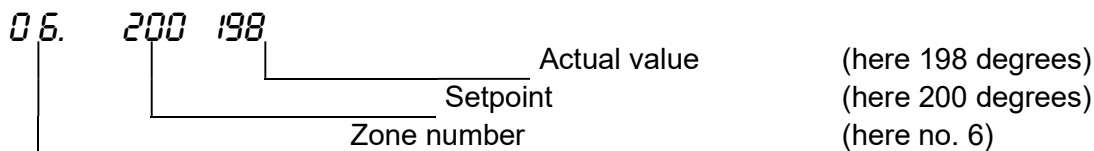

The reports of the total display are also indicated for the selected zone.

2.3.1 Locking / unlocking for settings

The variation of settings is depending on 4 different levels. These differ by the levels of enabled setting ranges. A higher level includes the lower level.

- Level 000 completely locked
- Level 001 variations of setpoints, operation mode and output rate
- Level 002 variations of the parameters, self tuning and Level 001
- Level 003 variations of the basic settings, nominal currents and Level 002

If a code >000 is entered via the basic parameters 9, 10 or 11, the referring levels may be locked. An unlocked level may be reset after switch off the unit or by trials with a wrong code.

2.3.2 Settings and variations

Settings have to follow this sequence:

P or **I** select the zone no,

P or **I** select the parameter no, the actual value is indicated,

T or **M** select the desired value.

→ In case of missing authority the actual level will be indicated. After setting the correct code, the parameter value will appear again.

T or **M** select the desired value.

E confirms the new setting.

2.3.3 Setpoints

(From level 001)

The setpoints are to set for the selected zone in the setting mode. The setpoint „000“turns the referring zone off. The resulting indication is „--- ---“. The supervision for high and low temperature is no more active, but the watchdog-function still switches off, if the temperature reaches the HI-value.

3 Settings for the unit

3.1 Selection of the operation mode

The keys **E** and **M** change the operation mode of the selected zone. The 3 modes are called in series and are immediately active.

<i>200</i>	<i>198</i>	Setpoint and actual value	Control mode
<i>OFF</i>			Zone turned off
<i>-P- [030.]</i>	<i>198</i>	Mode [output rate] and actual value	Manual mode (power mode)
<i>200</i>	<i>198</i>	Setpoint and actual value	Control mode

and so on

3.1.1 Zone OFF

This way zones may get turned off, if they are not needed temporarily or durably.

3.1.2 Setting of fixed output rates (manual mode)

In case of defective or missing sensor or other reasons it might be necessary to run a zone with a preset power rate. The values for this mode have to be set as usual. Heating rates are positive and cooling rates are negative values.

-P - [030.] 198 Mode [output rate] and actual Control mode value

3.1.3 Measuring zones

A control-loop may be used for indication, if a sensor is wired. The parameter 9 needs to be reduced to „0“. The alarm limits of the parameter 1, 2 and 3 are further on supervised.

3.2 Settings for all zones

This way a fast indication or variation of the actual commission is possible. A longer press on the **P** key at zone 1 enables the entry.

3.2.1 ID-Level

(From level 000)

Indication of the actual ID-Level. Via input of the referring code another level may get unlocked. After trials with a wrong code, the unit will return to level 000.

Text in INFO-display:	<i>ID-LEVEL</i>	
Setting limits:	000...999	
Original value	001	Level

3.2.2 Outputs

(From level 003)

Indication of the actual status of all outputs. **T** and **M** may switch all outputs ON or OFF.

Text in INFO-display:	<i>OUTPUTS</i>	
Setting limits:	ON / OFF	
Original value	ON	

3.2.3 Setpoint-program

(From level 002)

Indication of the actual setpoint-program. After change of the program all variations of setpoints are valid for the new program no. The variation of the temperature for all zones is possible in a simple way.

Text in INFO-display:	<i>Pr06-nUN</i>	
Setting limits:	001...004	
Original value	001	

4 Setting parameters

The **CRIS+** gets adjusted to specific controller requirements by the parameter mode. This mode offers 28 different parameters which are indicated and may get changed.

4.1 Parameter mode

To reach the parameter mode press **[E]** first and additionally **[P]** (at any zone). The display indicates in parameter mode:

The decimal points in the zone- and actual-display appear.

Example:

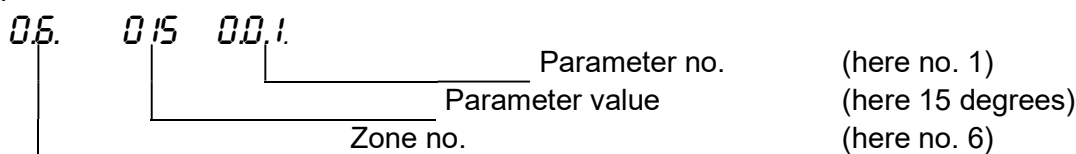

This example shows the low alarm limit at 15 degrees for zone no. 6.

4.1.1 Selection of parameters

Settings have to follow this sequence:

[P] or **[I]** select the zone no. or parameter no.,

[T] or **[M]** change the value,

[E] confirms the new setting.

If you overstep the first or last parameter of a zone, you will enter the parameters of the neighbour zone.

If the required level for the settings should be locked, the indication will step to basic parameter 1. Now set the necessary code to go on.

4.1.2 Leave parameter mode

To leave the parameter mode press **[E]** first and additionally **[P]**.

4.2 Definition of the parameters

The functions of the different parameters are described in the following.

4.2.1 Parameter 1: Lo Alarm

(From level 002)

Under passing the value set for parameter 1, the respective zone triggers LO-alarm. This is shown by a flashing „-L-“alternating with the actual value. The LED „L“lights and the alarm-relay switches.

Text in INFO-display:	<i>LO-ALARM</i>
Setting limits:	0...999 [°C]
Original value	0

4.2.2 Parameter 2: Hi Alarm

(From level 002)

Exceeding the value set for parameter 2, the respective zone triggers HI-alarm. This is shown by a flashing „-H-“alternating with the actual value. The high temperature-LED „H“lights and the alarm-relay switches.

Text in INFO-display:	<i>HI-ALARM</i>
Setting limits:	0...999 [°C]
Original value	400

The HI-alarm is not supervised at setpoint = 0!

4.2.3 Parameter 3: Deviation Alarm

(From level 002)

As soon as the actual value of a zone deviates from the setpoint by more than this setting here the respective zone triggers deviation alarm. This is shown by a flashing „-dL-“ or -dH- alternating with the actual value. The report-relay switches.

Text in INFO-display:	dEU ALARn
Setting limits:	1...999 [K]
Original value	15

4.2.4 Parameter 4: x_p Heating

(From level 002)

Parameter 4 allows the ' x_p ' of the controlled process to be set *in percent*. The resulting p-band derives from the set maximum value (standard 500°).

If, for example, a parameter value of 10 is set and the maximum value (adjustable at an other position) is 500°C, the effective p-band is 50°C. For a simple P-controller this means, that the output of 50% is slowly reduced before reaching the setpoint, so that it had reached 0% when SETPOINT = ACTUAL VALUE. This results in the following curve:

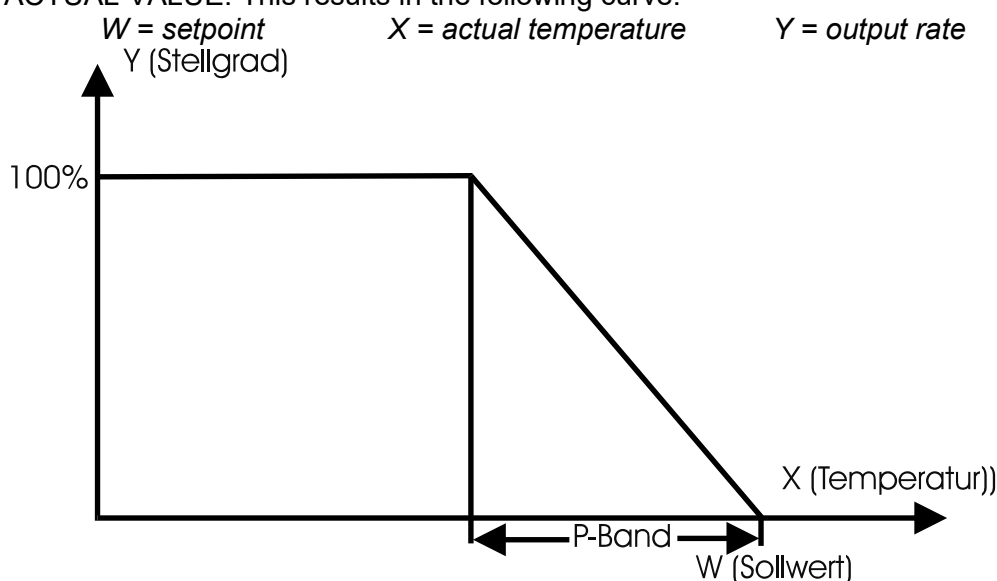

Text in INFO-display:	P HEAT
Setting limits:	0...999 [%] (0=P-part turned off)
Original value	5

4.2.5 Parameter 5: t_i (Integral part for heating)

(From level 002)

Parameter 5 allows the setting of the integral part of the controller in seconds. In the event of deviation this control part increases or decreases the output rate by a speed set here.

Text in INFO-display:	I HEAT
Setting limits:	0...999 [sec] (0=I-part turned off)
Original value	80

4.2.6 Parameter 6: t_d (Differential part for heating)

(From level 002)

Parameter 6 allows the setting of the differential part of the controller in seconds. This part 'brakes' the output for a time set here, if the actual value approaches the setpoint at too high speed.

Text in INFO-display:	d HEAT
Setting limits:	0...999 [sec] (0=D-part turned off)
Original value	13

4.2.7 Parameter 7: Heating ramp (From level 002)

A heating ramp can be set by parameter 7 if a smooth heating up of the medium is required. This is effective if:

- The unit has just been switched on.
- The setpoint has been increased.

The ramp effects a smooth changing of the *INTERNAL* setpoint towards the final setpoint. As soon as the *INTERNAL* setpoint has reached the final setpoint the ramp becomes inactive until the next setpoint variation.

Controlling always applies to the *INTERNAL* setpoint !!

The speed of the ramp for heating up will be set here in the unit sec/°C, this means that high values effect a slow ramp.

Speciality for „steam cooling“ (parameter 12=1): If there is a heating ramp defined the cooling will be ignored until the internal setpoint has reached the final setpoint. This is only valid during heating up, not for cooling down.

Text in INFO-display:	<i>rAMP UP</i>
Setting limits:	0...999 [sec/°C] (0=ramp passive)
Original value	0

4.2.8 Parameter 8: Cycle time heating (From level 003)

To reduce the output frequency to an acceptable value for example for contactors the parameter 8 has to be increased for longer cycle time.

An increase of this parameter effects slowing down the output frequency.

If the cycle time will be set to „0“, this zone gets configured to a measuring zone. No setpoint will be indicated and no deviation alarms are indicated.

Text in INFO-display:	<i>CYCLE H</i>
Setting limits:	1...20 [sec]
Original value	1

4.2.9 Parameter 9: Maximum output rate for heating (From level 003)

This parameter limits the output rate for the heaters.

Text in INFO-display:	<i>TOP-Y H</i>
Setting limits:	0...100 [%]
Original value	100

4.2.10 Parameter 10: Diagnosis time (From level 003)

For the plausibility check of the controller. (to find later on)

Text in INFO-display:	<i>DIAG-TIME</i>
Setting limits:	0...999 [sec]
Original value	0

If the setting is „0“ the check is turned off for this zone.

4.2.11 Parameter 11: Temperature drop (From level 001)

Only the option of digital inputs enables the activation of a temperature drop during operation. The temperature has to be set here. It will replace the setpoint of the actual program.

Text in INFO-display:	<i>StRndbY</i>
Setting limits:	0...999 [°C/°F]
Original value	0

4.2.12 Parameter 12: Cooling medium (From level 003)

The medium for cooling can be set by this parameter (0 = air or 1= steam). Air cooling results in a regular active/passive-ratio depending on the required cooling rate.

Steam cooling activates the cooling for the shortest possible time and the required cooling rate is achieved only by the variation of the cut-out time.

Speciality for „steam cooling“: If there is a heating ramp defined (parameter 7) the cooling will be ignored until the internal setpoint has reached the final setpoint. This is only valid during heating up, not for cooling down.

Text in INFO-display: *COOLSYSt*

Setting limits: 0 or 1

Original value 0 (air)

4.2.13 Parameter 13: Injection time for steam cooling (From level 003)

This parameter sets the time for injection in steps of 10 ms in case of steam cooling.

Text in INFO-display: *Ed-COOL*

Setting limits: 1..20 [10ms]

Original value 10

4.2.14 Parameter 14: xp cooling (From level 002)

Similar to parameter 4 (xp for heating) here the P-band is to set for cooling.

Text in INFO-display: *P COOL*

Setting limits: 1...100 [%]

Original value 5

4.2.15 Parameter 15: tj cooling (From level 002)

Similar to parameter 5 (ti for heating) here the I-part is to set for cooling.

Text in INFO-display: *tI COOL*

Setting limits: 0...999 [sec] (0=I-part turned off)

Original value 80

4.2.16 Parameter 16: td cooling (From level 002)

Similar to parameter 6 (td for heating) here the D-part is to set for cooling.

Text in INFO-display: *d COOL*

Setting limits: 0...999 [sec] (0=D-part turned off)

Original value 13

4.2.17 Parameter 17 Cooling ramp (From level 002)

In opposite to parameter 7 (ramp up) a ramp down may be set here, what means this ramp is only effective after decreasing the setpoint.

Text in INFO-display: *rRNP dn*

Setting limits: 0...999 [sec/K] (0=ramp disabled)

Original value 0

4.2.18 Parameter 18: cycle time cooling (From level 003)

Function in the mode “air cooling”:

For the referring zone in this mode (parameter 12=0) the cycle time for cooling may be set here, similar to parameter 8.

Text in INFO-display: *CYCLE C*

Setting limits: 1...100 [sec]

Original value 10

Function in the mode “steam cooling”:

For the referring zone in this mode (parameter 12=1) the cut out time for 100% cooling rate has to be set here.

Text in INFO-display:	<i>CYCLE C</i>
Setting limits:	1...100 [1/10sec]
Original value	10

4.2.19 Parameter 19: maximum cooling rate (From level 003)

Similar to parameter 9 the cooling rate may get limited here. The setting of „0“ turns off the cooling.

Text in INFO-display:	<i>TOP-Y C</i>
Setting limits:	0...100 [%]
Original value	100

4.2.20 Parameter 20: Mean output rate (From level 001)

This parameter defines itself during the normal control operation. It stores a mean output rate, which has been found during a long time of controlled operation.

Text in INFO-display:	<i>MEAN-Y</i>
Setting limits:	0...100 [%]
Original value	0

4.2.21 Parameter 21: Operation mode of the zone (From level 001)

Text in INFO-display:	<i>MODE</i>
Setting limits:	0 = Output turned off 1 = Manual mode 2 = Control mode
Original value	2

Remark: In manual mode „0“(outputs are turned off) the supervision of the zones is still active (LO-, HI- alarm and plausibility check). The setpoint must get set to „0“ to disable this supervision.

The mode „0“ is used if a zone is completely installed (heater and sensor) and not used temporary. If a zone is generally not used, then the setpoint has must get set to „0“.

4.2.22 Parameter 22: Preset for output rate (From level 001)

In preparation for a possible change to manual mode the output rate may be preset here. During control mode this parameter has no influence.

Text in INFO-display:	<i>SET-Y</i>
Setting limits:	-100 ... +100 [%]
Original value	0

4.2.23 Parameter 23: Type of sensor (From level 003)

Depending on the installed input-board the type of sensor and thus the linearisation can be selected here. The value set here must accord with the components on the input-board.

Text in INFO-display:	<i>SENSOR</i>
Setting limits:	1...4
Original value	3

The following codes are possible:

- 1 = Pt100 2 = NiCrNi type K 3 = FeCuNi TYP J 4 = FeCuNi TYP L

4.2.24 Parameter 24: Offset (From level 003)

The indicated actual value of the zone may be corrected by increasing or decreasing this parameter.

Text in INFO-display:	<i>OFFSEt</i>
Setting limits:	-99...100
Original value	0

4.2.25 Parameter 25: Setpoint-ramp (From level 003)

The variability of the output rate may be limited by this parameter. The unit of the setting is %/sec. Smaller values can make a control-loop smooth but inert.

Text in INFO-display:	<i>SrRnP</i>
Setting limits:	1...100
Original value	100

4.2.26 Parameter 26: Solution of the cooling rate (From level 003)

The solution for the cooling output rate may be changed here.

Text in INFO-display:	<i>SLEP C</i>
Setting limits:	2 ...100 [steps for 100%]
Original value	10

A rough setting reduces the accuracy of the cooling. A fine solution leads to short switching periods at small or great output rates. So there has to be set a compromise.

4.2.27 Parameter 27: Nominal current of the heater (From level 003)

The nominal current of the heater will be stored by this parameter. The setting „0“ turns the supervision of the current off.

Text in INFO-display:	<i>ISEt</i>
Setting limits:	0...999 [1/10A]
Original value	0 no supervision

4.2.28 Parameter 28: Range of tolerance for the current (From level 003)

The sensibility of the current supervision is set here by % of the nominal current (parameter 27). Heater currents are recognised from 0.1A.

Text in INFO-display:	<i>ITOL</i>
Setting limits:	5...100 [%]
Original value	10

4.2.29 Parameter 29: Scaling analogue input (From level 002)

For the version with analogue inputs, this parameter sets the final value for a signal of 10VDC. (decimal point see parameter 30)

Text in INFO-Display:	<i>SCAL InS</i>
Setting limits:	1...999
Original value	999

4.2.30 Parameter 30: Decimal scaling (From level 002)

This parameter may set a decimal point for the scaling (parameter 29).

Text in INFO-Display:	<i>FornRt</i>
Setting limits:	0...2
Original value	0

4.3 Definition of the basic parameters

The basic parameters are used for basic settings of the controller. A longer press on the **[P]** key at the 1st zone enters the basic parameters. They are to find below the settings for the zones. The functions of these parameters are described in the following.

4.3.1 Basic parameter: Alarm delay

(From level 003)

Indication of the actual alarm delay. A delay of the alarms and reports gets set in seconds.

Text in INFO-display:	<i>AL DELAY</i>
Setting limits:	0...999 [sec]
Original value	0

4.3.2 Basic parameter: First zone no. (From level 001)

Indication of the actual number for the first zone. Up to 99 zones may get numbered continuously in case of several devices.

Text in INFO-display:	<i>20nE 1</i>
Setting limits:	001...085
Original value	001

4.3.3 Basic parameter: Upper setpoint limit (HI-value) (From level 003)

Indication of the actual upper limit for setpoints. Variations influence the settings of the parameters 4 and 14. The maximum value for this parameter depends on the type of sensor; Fe-CuNi up to 700 degrees C, NiCr-Ni up to 999 degrees C, PT100 up to 250 degrees C

Text in INFO-display:	<i>TOP SETP</i>
Setting limits:	0...999 [°C]
Original value	500

4.3.4 Basic parameter: Celsius/Fahrenheit (From level 003)

Indication of the actual temperature presentation.

Text in INFO-display:	<i>[CEL-FAHr</i>
Setting limits:	C / F
Original value	C

4.3.5 Basic parameter: Net frequency (From level 002)

Indication of the actual setting for the net frequency. The setting is important for the accuracy of the controller.

Text in INFO-display:	<i>50-60Hz</i>
Setting limits:	50 / 60 [Hz]
Original value	50 Hz

4.3.6 Basic parameter: Code for level 001 (From level 003)

Setting for a new code for the level 001.

Text in INFO-display:	<i>SETCODE 1</i>
Setting limits:	0...999
Original value	11

4.3.7 Basic parameter: Code for level 002 (From level 003)

Setting for a new code for the level 002.

Text in INFO-display:	<i>SETCODE 2</i>
Setting limits:	0...999
Original value	12

4.3.8 Basic parameter: Code for level 003 (From level 003)

Setting for a new code for the level 003.

Text in INFO-display:	<i>SETCODE 3</i>
Setting limits:	0...999
Original value	13

4.3.9 Basic parameter: Bus-address (From level 003)

Indication of the actual address for the serial interface.

Text in INFO-display:	<i>BUSAdrESS</i>
Setting limits:	001...030
Original value	001

5 Further functions

5.1 Watchdog-function

The watchdog-function operates as supervision and checks the processor and the components. It will disable the system-relay. All functions of the controller have to be ignored. That is why the supply of the outputs should get interrupted.

5.2 Indication of internal setpoints and output rates

By simultaneous press on **T** and **M** in the display appear:

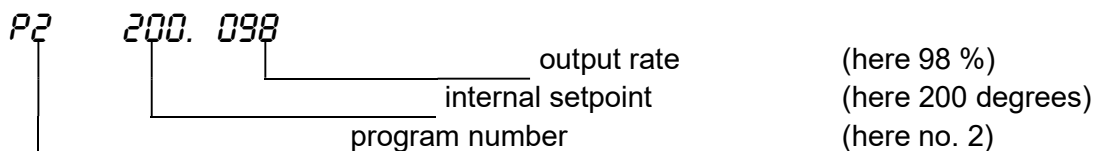

5.3 Indication of the software data

By simultaneous press of **P** and **M** the display shows the version data.

P2 704	program no.	(here 704)
UE- 1.00	version no.	(here 1.00)
02.10. 98	date of the software	(here 02.10.98)

5.4 Self-tuning of the control-zones

(From Level 002)

Using the installed selftuning-routine the **CR15+** is able to analyse the wired control loops and modify the P-, I- and D-parts of the controller by an adapted algorithm. 3 different routines are installed for the tuning.

The routine is indicated in the referring zone by \bar{t} . If the routine is cancelled without result, the referring zone reports $\bar{t}\bar{E}$.

5.4.1 Self tuning of the heating by startup method

The self tuning by the startup method should always be started from a stable cold state. In case of slow heating zones, which are possibly muting one another (e.g. extruder barrels), this will be the only method.

At the start of the tuning process the output is set to 100% at the beginning. The process will get stopped without variation of parameters, if

- the actual value increases 80% of the setpoint and no v_{max} was found out (risk to overheat)
- the actual temperature decreases in spite of 100% heating (wrong effect)
- the actual increase of temperature is more than $1^\circ / \text{sec}$ / risk of overtemperature)

A wrong result will be the consequence of:

- the temperature was decreasing at start of self tuning e.g. by cooling the zone
- the heating was switched off by external contactors at start of self tuning (what results in a wrong delay time)
- the temperature was increasing at start of self tuning e.g. by previous heating up (result is a too short delay time).

To avoid the above mentioned faults during the self tuning process, the following procedure is proposed:

- Switch off all heaters by OUTPUTS = OFF (2nd basic parameter) after start of the unit.
- Set the setpoints of the zones that shall be tuned to the value of normal operation temperature.
- Wait until all heaters are in a stable cold condition.
- Start the tuning for the relevant zones by the keys **E** and **T** .
- Enable the outputs (2nd basic parameter).

A limitation of the output rate will get ignored.

5.4.2 Self tuning of the cooling zone by the drop-set method

Only when cooling is installed and enabled by the parameter 19, tuning by the drop-set method is possible. The actual values should be close to the setpoints.

The self tuning process will get stopped without variation of the control parameters if:

- the actual value decreases below 80% of the setpoint and no v_{max} was found
- the actual value increases in spite of 100% cooling output (wrong effect)
- the actual temperature decrease is $> 1^\circ / \text{sec}$.

A limitation of the output rate (parameter 19) will get ignored.

5.4.3 Tuning the zone by the oscillation procedure

The oscillation procedure should also be started close to the process-setpoints. To start this procedure it is necessary to turn off the cooling for the referring zones (parameter 19 = 0).

After increasing below the setpoint the oscillation will be carried out with full heating power.

Disadvantage: Very big and very slow zones (e.g. ovens) are not able to get tuned in an acceptable time in cause of the low frequency. Thermal coupled zones (e.g. barrel zones of extruders) influence one another, so the calculation will fail. A tuning zone after zone may give better results in this case.

A limitation of the output rate (parameter 19) will get ignored.

5.5 Reset to the original parameters

ATTENTION: This function resets all settings and setpoints to the status of origin. It is required to enter the parameter mode and press the following 3 keys together for 3 sec :

E and **T** and **M** . Then a restart of the unit follows.

6 Commissioning

Some important settings and wirings have to be done or checked before the first start.

6.1 Definition of the terminals

6.1.1 Sensor inputs

Wiring of thermocouples (Fe-CuNi or NiCr-Ni) to **CR15+**

Part of the rear view

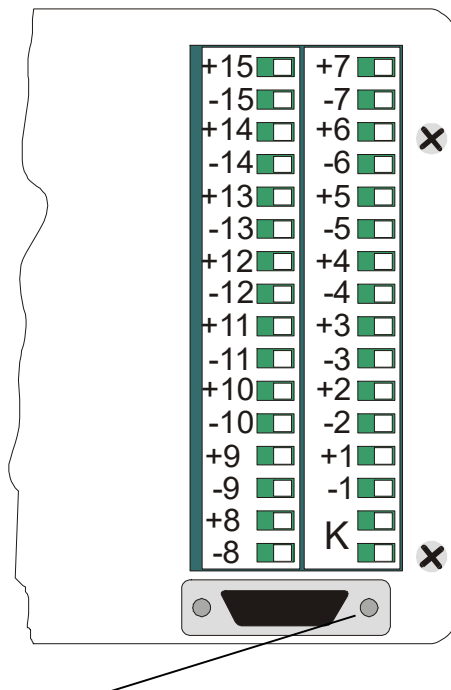

Plug for program selection and current-signal

(K = compensating resistor; is internally mounted and will only be separated for special fittings. In this case it has to be wired via these terminals.

Wiring of thermo resistors (Pt100 2wire) for **CR15+**

Part of the rear view

Not wired inputs should get linked to protect against EMC disturbances.

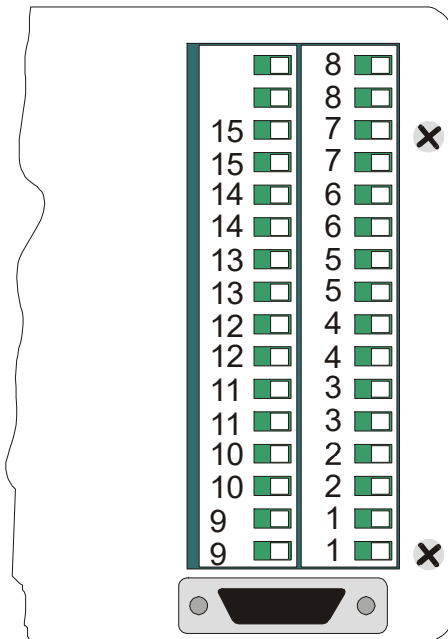

Wiring of thermo resistors (Pt100 3wire) for **CR15+**

Part of the rear view

Because of the required number of terminals (3x15 terminals) the Pt100 3wire-sensors are connected via a 50 pins Sub-D plug. For easy wiring the **FELLER ENGINEERING** offers suitable interface cables and terminal-modules for connection of the Pt100 cables.

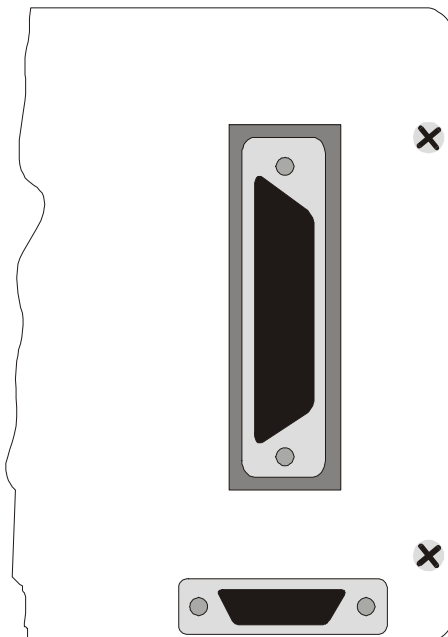

6.1.2 Power outputs (heating and cooling)

Definition of the terminals for TRIAC-outputs (230V AC)

Collective fuses 16A
output max.3A

!!!
The supply of the boards via the terminal „L“ has to be limited to max. 8A.

Using the 2nd „L“ terminal for further supplies the maximum current limit has to be observed.
!!!

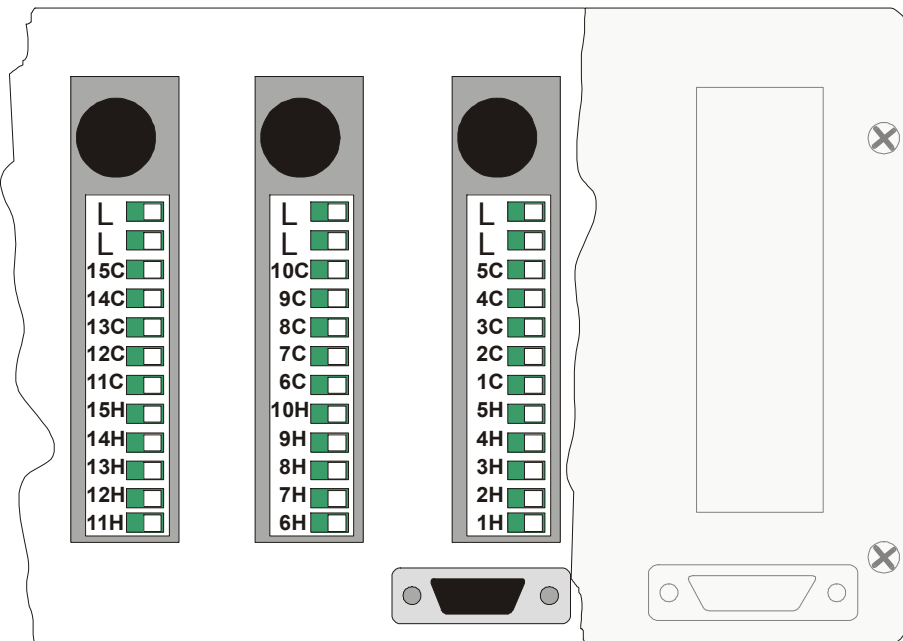

The 3 output-boards are electrically isolated from each other as well as from the unit itself. That is why the 3 boards have to get supplied separately. For 3-phase installation the 3 boards may be used for the 3 phases(L1, L2, L3).

Collective fuses 6A
output max.1A

!!!
The supply of the boards via the terminal „L“ has to be limited to max. 8A.

Using the 2nd „L“ terminal for further supplies the maximum current limit has to be observed.
!!!

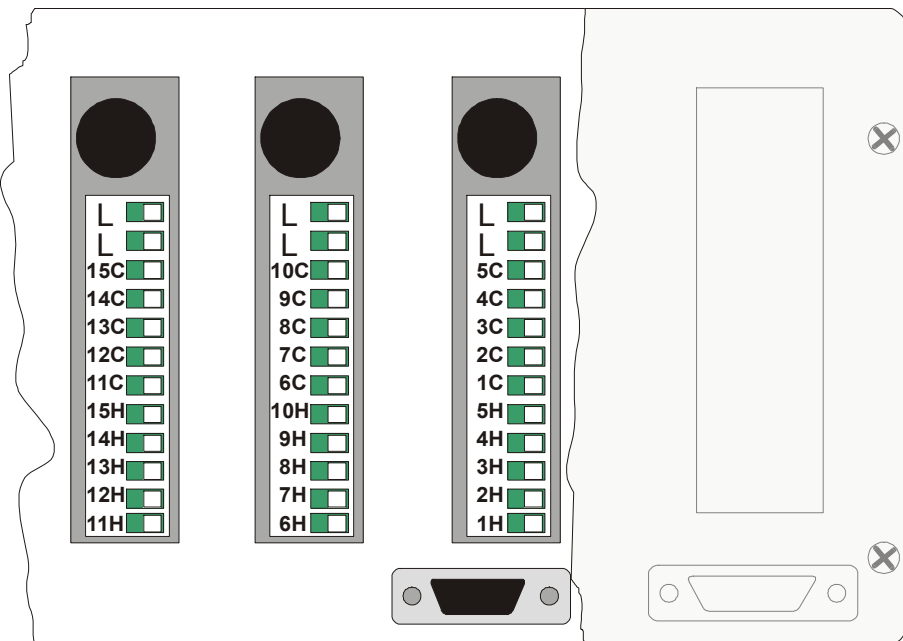

Definition of the terminals for low-voltage outputs (24 V DC)

6.1.3 Net supply and alarm-outputs

Net supply 24 VAC, 110 VAC or 230 VAC

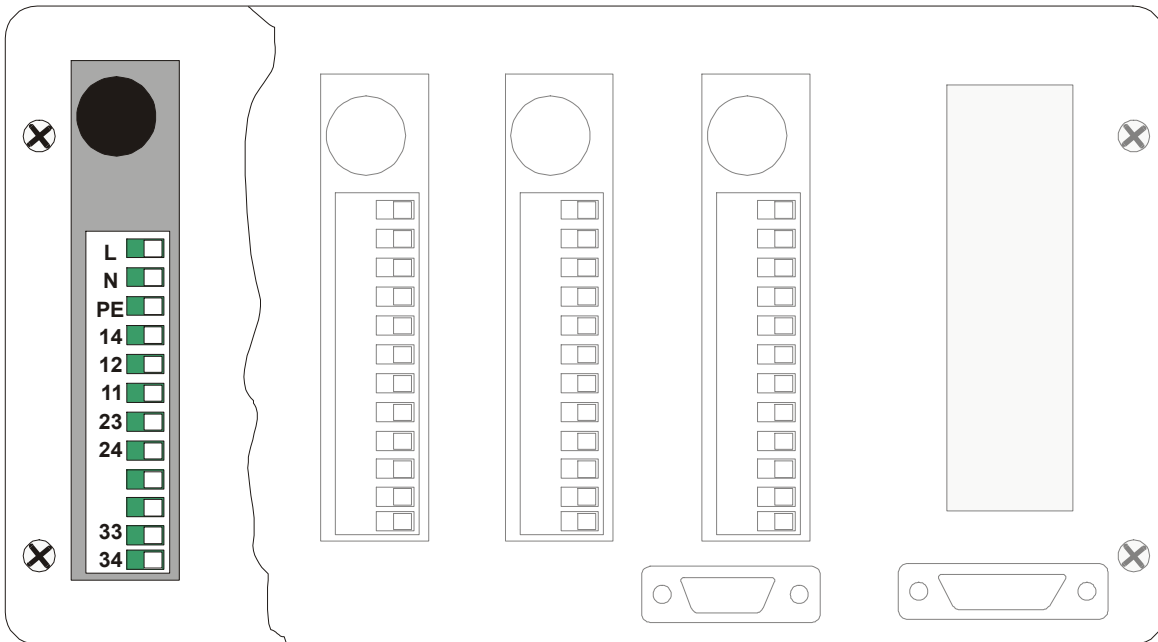

At non stable net supply a voltage stabilizer has to be used!

Net supply 24 V DC

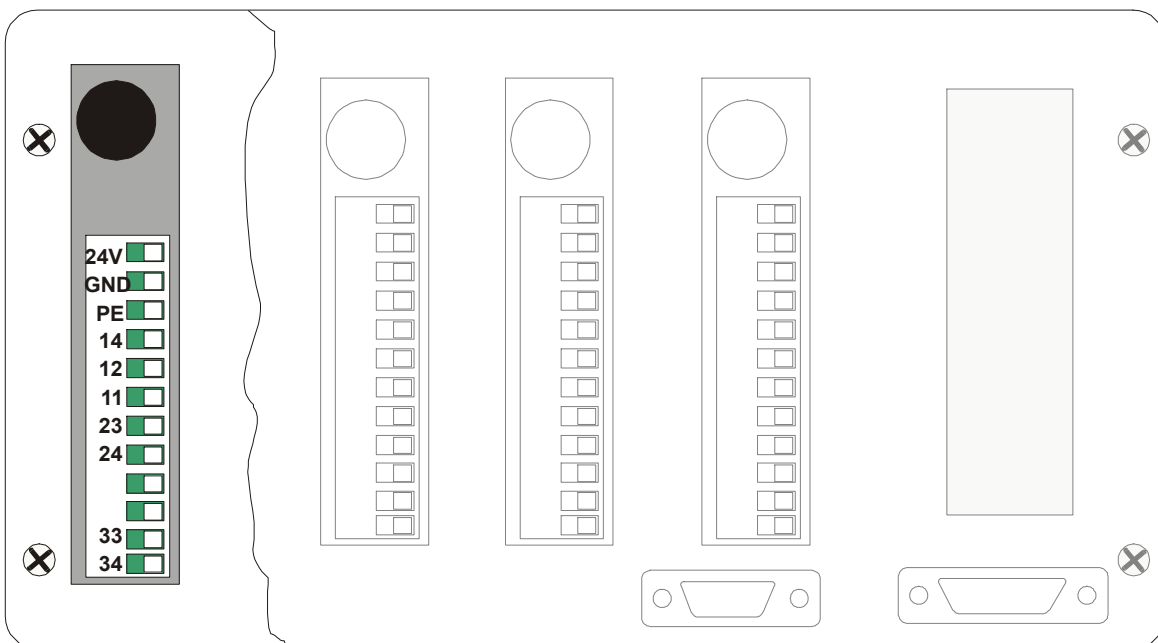

6.1.4 Relay-contacts

Alarm-contact

Relay 1 = (active with alarm; normally 11-12 closed)

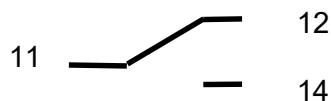

Report-contact

Relay 2 = (active with alarm; normally opened)



System-contact

Watchdog = (inactive with watchdog; normally closed)



6.1.5 Plug for heater-current transmitter **AT083**

The module is an optional equipment. It is wired to the **CR15+** by the cable **AU026**.

6.1.6 Digital-In

The CR15+ is fit with digital parallel inputs. This is the option for remote selection of the 4 setpoint programs.

The plug for the current-signal is fit with further functions. Using the module **AT083** these functions are available by terminals on the module.

Pin-definition CR15+	Terminal AT083	Function
1	S1	Selection setpoint-program 1
2	S2	Selection setpoint-program 2
3	S3	Selection setpoint-program 3
4	S4	Selection setpoint-program 4
5	S7	Interlock for the outputs
6	S8	Drop set
10..15	GND	Ground

The inputs are designed for a PLC-compatible level of 13..30 VDC at a mean load of 8,5mA.

The remote selection of the program happens via Digital-In. The control voltage (24VDC against GND) has to be contacted to the corresponding input (pin 1..4 for the desired program). A short contact (0,1sec) selects the program and a continuous contact interlocks the front-keys.

6.2 Heater-current measuring

A signal converter **AT064** and a transmission module **AT083** are required for measuring of the heater-currents. The DIP-switch no.1 of the bloc C must be in the position ON for this function. The DIP-switches are to reach from the top of the **CR15+**.

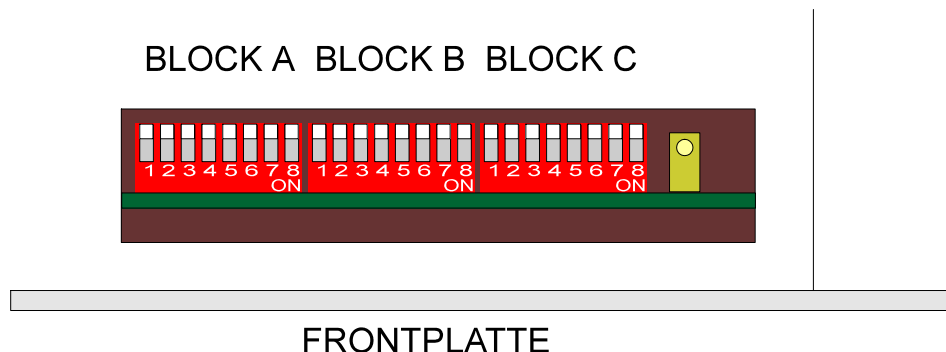

There are 2 covers on the top of the unit. The 3 blocs of 8 DIP-switches are below the fore plate. The heater current supervision also detects an uncontrolled permanent current, that is not controlled by **CR15+**. A defective power relay has to be located for the reason.

55r LED „WD“ at all zones

The watchdog contact switches and has to be confirmed by the Enter-key for reset.

6.2.1 Start of the heater-current supervision

(From level 002)

To enable the current supervision the nominal currents have to be stored for the referring zones. This happens either directly via parameter 27 or by teaching all zones simultaneously. In the display mode „IX“ the keys **E** and **I** have to get pressed for teaching. The indication **!LEArn** confirms the settings.

The accuracy of the supervision has to be set in % of the nominal current via parameter 28. It is important for small current values to observe that floating current values at non stable net supply may result in alarms.

6.3 Plausibility check

The controller can supervise the reaction of the activated zones, if the diagnosis time (parameter 10) is set.

6.3.1 Recognition of shorted thermocouples

-5- LED „S“ Shorted sensor at this zone

A shorted sensor will get alarmed, if:

- the actual value is below the deviation alarm limit or low alarm is already signalled
- and the controller requires 100% output rate during the diagnosis time set by parameter 10
- and within this time the temperature does not increase by at least 5 KELVIN
- and the zone is in control- or drop-set-mode
- and the setpoint is > „0“.

This procedure also recognizes wrong poled sensors and defective heaters!

The consequence of this alarm the heaters get turned off. The alarm-relay switches at the same time.

The acknowledge of this alarm has to be done by

- a short off and on via supply voltage (collective acknowledge)
- or a variation with new setting of the setpoint for the referring zone (via serial interface).

This alarm will occur in case of disabled heaters by a separate relay or disconnected plugs.

6.3.2 Recognition of defective (shorted) actuators

55r LED „H“ Defective actuator (Solid State Relay) at this zone

A shorted actuator is signalled, if

- the zone is in control mode
- and the regulation rate for the output is reduced to the minimum (parameter 19)
- and the actual temperature increases 5 K above the dH-alarm (parameter 3)
- and the duration for this 5K is below the stored diagnosis time (parameter 10).

This alarm switches the alarm-relay. The alarm must get confirmed by the E key.

7 Technical data and dimensions

Number of control loops	5, 10 or 15 zones depending on the extension
Outputs	Industrial-TRIACS, impulse controlled, each output max. load 230V / 3A; each group max. 6 A, SF = 80%
Range of temperature	0-700 Grad C at Fe-CuNi 0-999 Grad C at NiCr-Ni 0-250 Grad C at thermo resistors (Pt100)
Sensor inputs	Fe-CuNi, NiCr-Ni with linearisation by software Option: Pt100
Ambient temperature according to EN 60204	+5°C to 40°C up to 1000m above sea level at a daily average of max. 35°C. For higher temperatures the surface temperature shall not increase 50°C.
Power consumption	14...25 W, depending on the load of the outputs
Control algorithm	PI, PD or PID, control parameters for each zone separate
Relay contacts	each max. 230 VAC / 3 A
Fuses	outputs, for each board 6 A FF super fast (6,35 x 32 mm) control voltage 1 x 0,5 A M medium (for 24VDC 1 x 0,8 A) (6,35 x 32 mm)
Net supply	outputs 3 x 230V, 6A control voltage 230V +5% / -10%, 20VA optional 115 VAC, 24 VAC or 24 VDC
Dimensions	front plate - Rack-version (19"-version) 3 HE = 128,4 mm 42 TE = 213,0 mm front plate - Cabinet-version 3 HE = 128,4 mm width = 230,0 mm depth without terminals = 215,0 mm with terminals = 230,0 mm with straight interface-plug = 255,0 mm
Weight	Cabinet break out H 114,4 x W 214,0 mm depending on the extension 2,5 to 3,0 Kg

Front view and dimensions **CR15+** - Rack-version

Front view and dimensions **CR15+** - Cabinet-version

8 Special extensions

Special extensions of **CR15+** get designed for different applications. Additional features will be described in an appendix, if they are not part of this manual.

9 Equipment

9.1 Current measuring via **AT083**, **AT064** and **AU026**

The transmission module **AT083** has to be wired to the **CR15+** by the cable **AU026**. The current-signal will be taken from the converter **AT064**. The signal is a summary of all required converters. The outputs have to be wired serially:

e.g. 1 converter module

Transmission module

Cable **AU026**

Controller

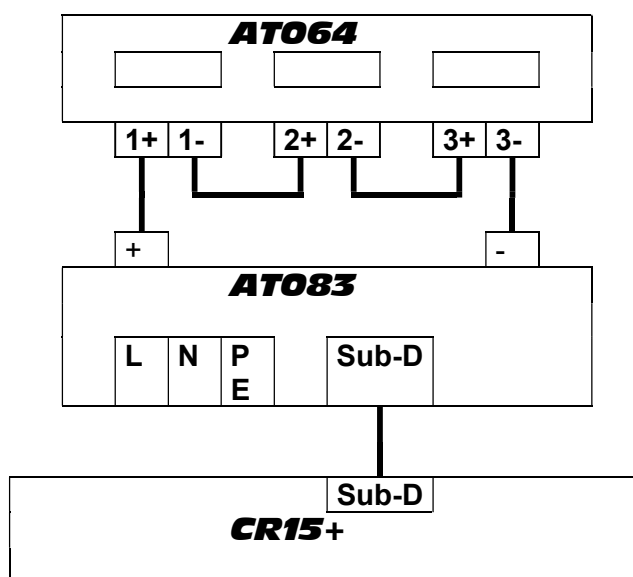

10 Serial interface

The **CR15+** is available with different types of data interface according to the request of the customer.

The location of the interface socket may differ, depending on the interface and the type of input board. A 9-fold Sub-D socket is mounted at the rear side. The definition for the pins depends on the different interfaces as described in the following.

Die Anordnung der Anschlussbuchsen an der Geräterückseite kann je nach gewählter Schnittstellenart und in Kombination mit der gewählten Eingangskarte unterschiedlich sein. Die Pin-Belegungen hängt von der Schnittstelle ab.

- PC-interface RS485 (default)
- PC-interface RS232
- RS422
- TTY 20mA / Current Loop

10.1 RS485 (default)

The interface RS485 enables the remote control of the 30 unit via 2 core cable. To guarantee a safe communication a twisted data-cable with screen has to be used. The data-cable has to be fitted with a 100 Ohm resistor at each end between the wires „A“ and „B“. The resistor is included in the

interface transformer **SI13** or the PC-input board from **FELLER ENGINEERING**. The max. length of the cable is 1200m.

Definition of the interface-socket:

Only the pins 2 and 3 are used.

(2 = TX+ respective "A"; 3 = TX- respective "B")

CR15+	
A(TX+)	2
B(TX-)	3

10.2 RS232

The interface RS232 enables the remote control of the unit via 3 core cable. To guarantee a safe communication a twisted data-cable with screen has to be used. The max. length is 15m.

Definition of the interface-socket:

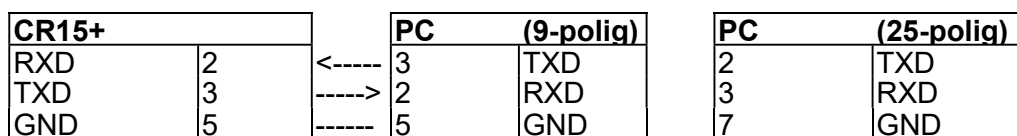

10.3 RS422

Definition of the interface-socket:

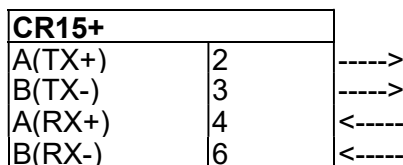

10.4 20mA Current loop

Definition of the interface-socket:

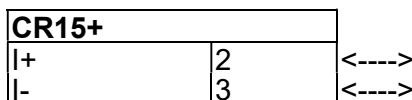

11 Declaration of EC-Conformity

referring to the following EC standards:

EC-Standard Electromagnetic Tolerance 2004/108/EG

EC-Standard Electrical Appliance 2006/95/EG

Maker:

FELLER ENGINEERING GmbH

CARL-ZEISS-STR. 14
63322 RÖDERMARK/GERMANY
TEL.: +49(6074)8949-0
FAX: +49(6074)8949-49
www.fellereng.de

Herewith we declare by signature, that the following described product confirm to the above mentioned EC standards referring design, production and distribution.

Further applied standards, as far as applicable:

EN 60204 part 1 (Electrical equipment for machinery),
EN 61000-6-1 (EMC immunity), EN 61000-6-3 (EMC radiation)

Product:

Multi-Channel-System temperature controllers *CR* -series

Product name:

CR5, CR10, CR15
CRxxplus

Year of first CE-sign:

1996

Rödermark, January 29, 2010

Quality supervisor

Registergericht Offenbach HRB 31367, Geschäftsführer: Dieter Skedzun