

AT267

2-Channel DMS-Amplifier Module with Digital Indicator

User Manual

Firmware V1.04

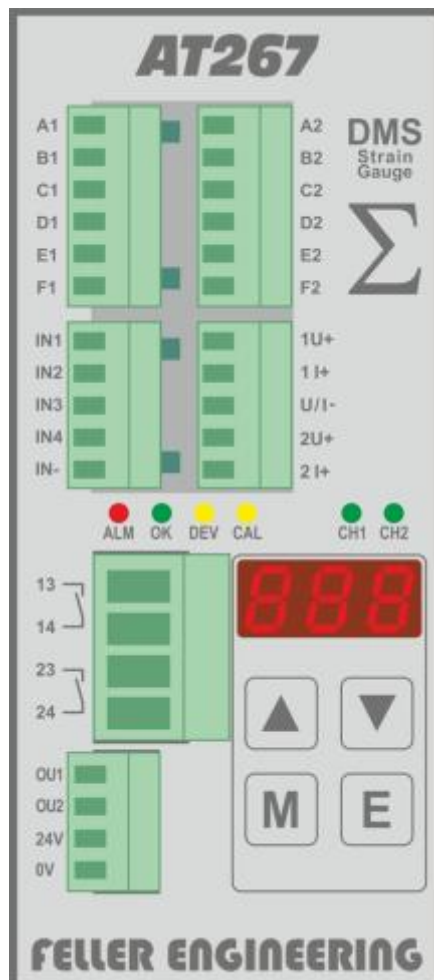

Contents

1	Short Description.....	4
1.1	Used symbols:	4
1.2	Block diagram	5
1.3	Quick Start	6
1.3.1	Electrical connection	6
1.3.2	Adjustment of the module to the used sensor	6
1.3.3	Calibrating the module	6
1.3.4	Adjustment to specific demands	6
2	Important Hints.....	7
2.1	General Safety Hints	7
2.2	Electrical Connection	7
3	Commissioning.....	8
3.1	Shutdown	8
4	Service and Care	9
4.1	Spares	9
4.2	Dimensions and Hints for Mounting	9
5	Contact Assignment, Indication- and Operating-Elements	10
5.1	Application of the terminal strips	10
5.2	Types of Connections	11
5.2.1	General Hints for the coded plugs	11
5.2.2	Realization of the Wiring	11
5.2.2.1	X1: DMS-strain gauge 1	11
5.2.2.2	X2: DMS-strain gauge 2.....	11
5.2.2.3	X3: Digital Inputs.....	11
5.2.2.4	X4: Analogue Outputs.....	12
5.2.2.5	X5: Alarm Contacts.....	12
5.2.2.6	X6: Digital Outputs.....	12
5.2.2.7	X6: Power supply.....	13
5.3	Status LEDs	13
5.4	7-Segment Display	13
5.5	Operation Keys	14
6	Operation of <i>AT267</i>	15
6.1	Power the Module	15
6.2	Indication of the Measured Value	15
6.4	Indication of Parameter Values	15
6.5	Change Parameters	15
6.5.1	Unlock	15
6.5.2	Setting Values	15
6.6	Acknowledgement of failures	16
6.7	Reset to default Settings	16
6.8	Parameter List	17
6.9	Detailed Description of the Parameters	18
7	Failure codes	23
7.1	Failure codes in the display	23
7.2	Warning messages	26
7.3	Behavior of the outputs in case of an error	27
8	Commissioning and Configuration	28

8.1	Calibration of DMS-Strain Gauge	28
8.1.1	Appropriate DMS-Strain Gauges	28
8.2	Calibration Routine	29
8.2.1	Start of the Calibration Routine by the Digital Input	29
8.2.2	Start of the Calibration Routine via Operation Keys	29
8.2.3	Important note after calibration	30
8.2.4	Indication of the Calibration Results	30
9	Appendix	31
9.1	Definition „NAMUR NE43“	31
9.2	Optional accessories	32
9.2.1	Mounting bracket with shield clamps and PE connection	32
9.3	Technical Data	33
9.4	Service Address	34
9.5	Customized parameters	35

1 Short Description

The module is designed to receive the signals from two strain gauge bridges and to deliver actual values and status information for further processing on the automation level. Therefore two analog outputs (in each case current and voltage), two digital outputs 24V as well as two dry relay contacts are available.

The function of the AT267 specially monitors the two bearing-strengths, which are transmitted from the bearings of a pull-roll. The analog output delivers the sum of the measured values of the two gauges. There is an alarm available, if the sum of both signals or the difference of the two signals (unbalanced status) exceeds a limit. The default settings create an alarm in case of a defective sensor (broken wire or shorted wires). Alarm delays are adjustable.

The device includes a three-digit 7-segments display to indicate measured values and settings. Important status information will be indicated by six LEDs with different colors at the front of the unit. For local operation the device provides four keys in front. These keys are used to set the device parameters, to indicate values and to start the calibration routine. Furthermore AT267 includes 24V inputs which are used for calibration and the acknowledgement of alarms.

The module is designed for mounting inside a control cabinet on a mounting rail type TS35 which . For power supply 24 VDC (5W) need to be connected.

All contacts are available from the front side via coded connectors.

The unit was designed according to the following rules:

EMC-policy referring to 2014/30/EU

Low voltage policy referring to 2014/35/EU

1.1 Used symbols:



Attention: Disregarding of this warning may cause troubles or failed functions.

Alarm: Disregarding of this warning may cause personal injury and/or mechanical damage.

1.2 Block diagram

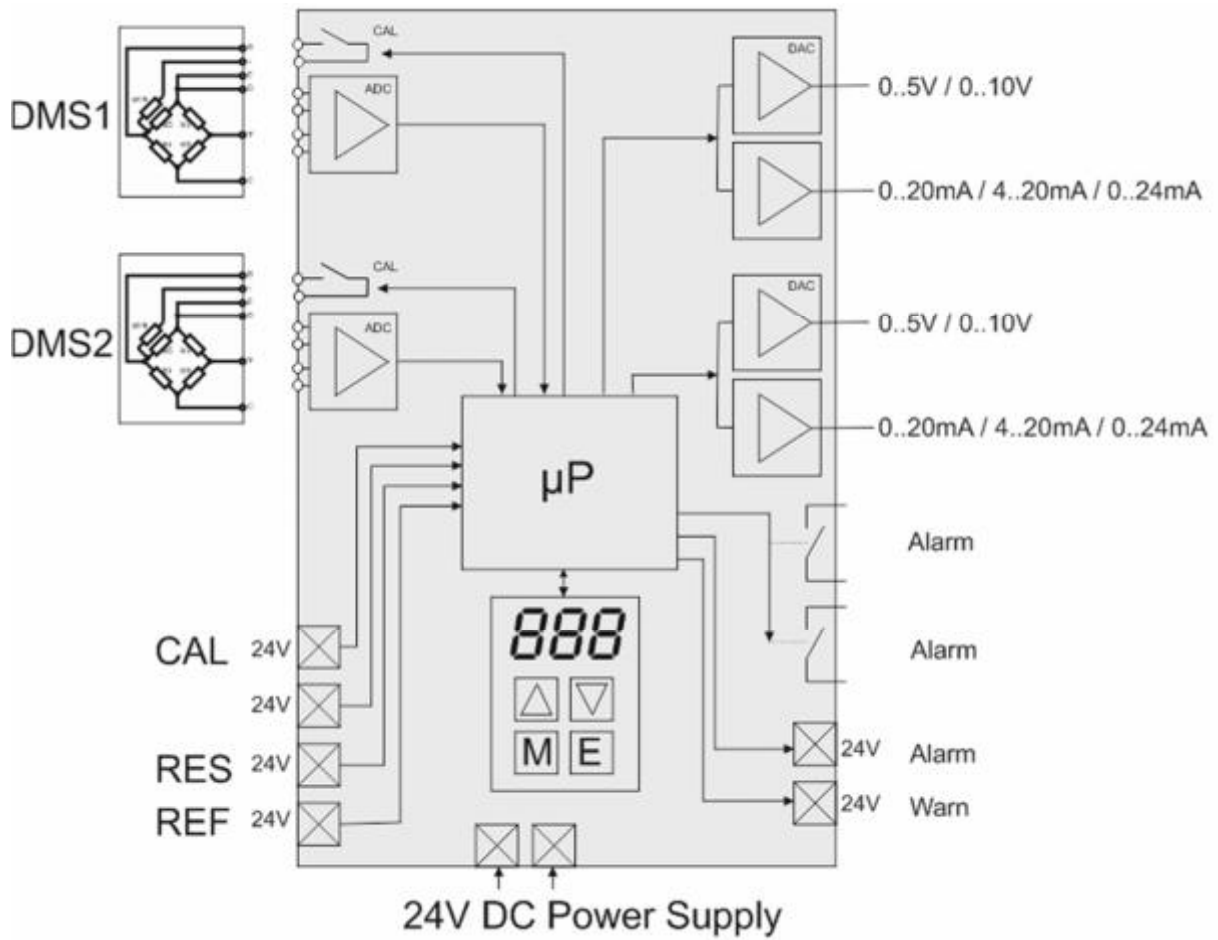

1.3 Quick Start

Observing the following steps, the module can be commissioned quickly and successfully.

1.3.1 Electrical connection

Connect both sensors to terminal X1 and X2 (chapter 5.2.2.1 and 5.2.2.2)

Connect current output 4...20mA to detect the measured value (chapter 5.2.2.4) or
– if it isn't necessary – switch off by parameter *low* = 0 (chapter 6.5).

Connect voltage source 24VDC to terminal X6 (chapter 5.2.2.7)

1.3.2 Adjustment of the module to the used sensor

Determine the nominal measuring force (e.g. 500 Newton) of each sensor using the type labels. The sum of both nominal measuring forces needs to be entered to in parameter *Ab5* (chapter 6.5)



1.3.3 Calibrating the module

Perform calibration according to chapter 8.2.

Now the module displays the pressure detected by the sensors.

1.3.4 Adjustment to specific demands

By setting specific alarm limits, connecting digital inputs and outputs as well as analog outputs, the module can be precisely adapted to the respective demands. The following chapters deliver further descriptions regarding this adjustment.

2 Important Hints

2.1 General Safety Hints

This unit is designed for industrial purposes to mount into a control cabinet.



All electrical connections have to be fit by an electrician! Commissioning and operation during the process are only allowed for authorized specialists!

Further hints regarding safety are marked in the referring chapters of the document. The unit was thoroughly checked before delivery and has passed the checkups of the maker's test-routine referring to the legal quality standards. To enable a reliable and riskless process, each user is bound to follow the hints and warnings. In case of charging sub-contractors, this document has to be handed over with the hints to follow. Manufacturer and supplier of this unit are not reliable for direct and indirect damage in case of irregular handling or usage of this unit.

2.2 Electrical Connection

The electrical wiring has to respect the referring local regulations and the standards of the plant. The wiring for signals has to be kept separately from the power supply. The unit is designed for a power supply via fuse.



It must be possible to disconnect the unit completely from the power supply! The unit has to be located as far as possible from disturbing sources. The wiring for signals has to be screened. The screen has to be connected to the chassis ground at only one end.

3 Commissioning

The following items have to be respected before first powering:



The power supply voltage for this unit, the voltage of the relay contacts as well as the control voltage of the digital in- and outputs has to correspond with the data of the type label resp. this documentation! The unit might only be used in regularly mounted status! The ventilation breakouts shall not be covered. The specified ambient conditions have to be guaranteed before and during the operation!

3.1 Shutdown

As the relay contacts are in NO-condition without power supply and the 24VDC outputs are at 0V, the status “alarm” will be set to the control level.



Before shutdown of the unit, it has to be ensured, that the depending controls don't create an irregular status.

4 Service and Care

There is no special service or care required. Exchangeable wear parts or adjustable mechanical parts are not present. For calibration of the DMS strain gauges there is no access to the interior of the module required.

4.1 Spares

There belongs a set of matching terminal connectors to each unit. These are coded and match only to the referring contacts. There is no mismatching possible. This is important in case of exchange of a unit. If any of these connectors might get lost, it is possible to order spares from the maker.



It is not allowed to use standard connectors without coding, as these may damage the counterpart at the unit.

Please contact the service address mentioned in this manual for spares and further information.

4.2 Dimensions and Hints for Mounting

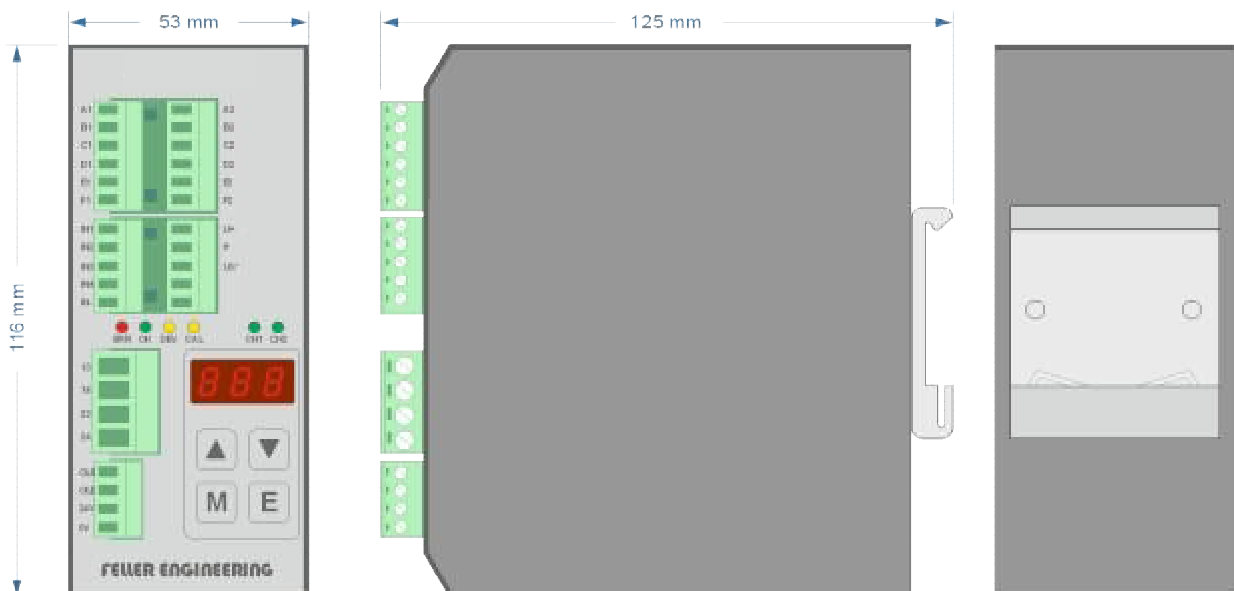

5 Contact Assignment, Indication- and Operating-Elements

The module uses different connections, 6 status LEDs, a 7-segment display and a section with 4 operating keys. These are to find at the front side of the unit as shows in the picture below.

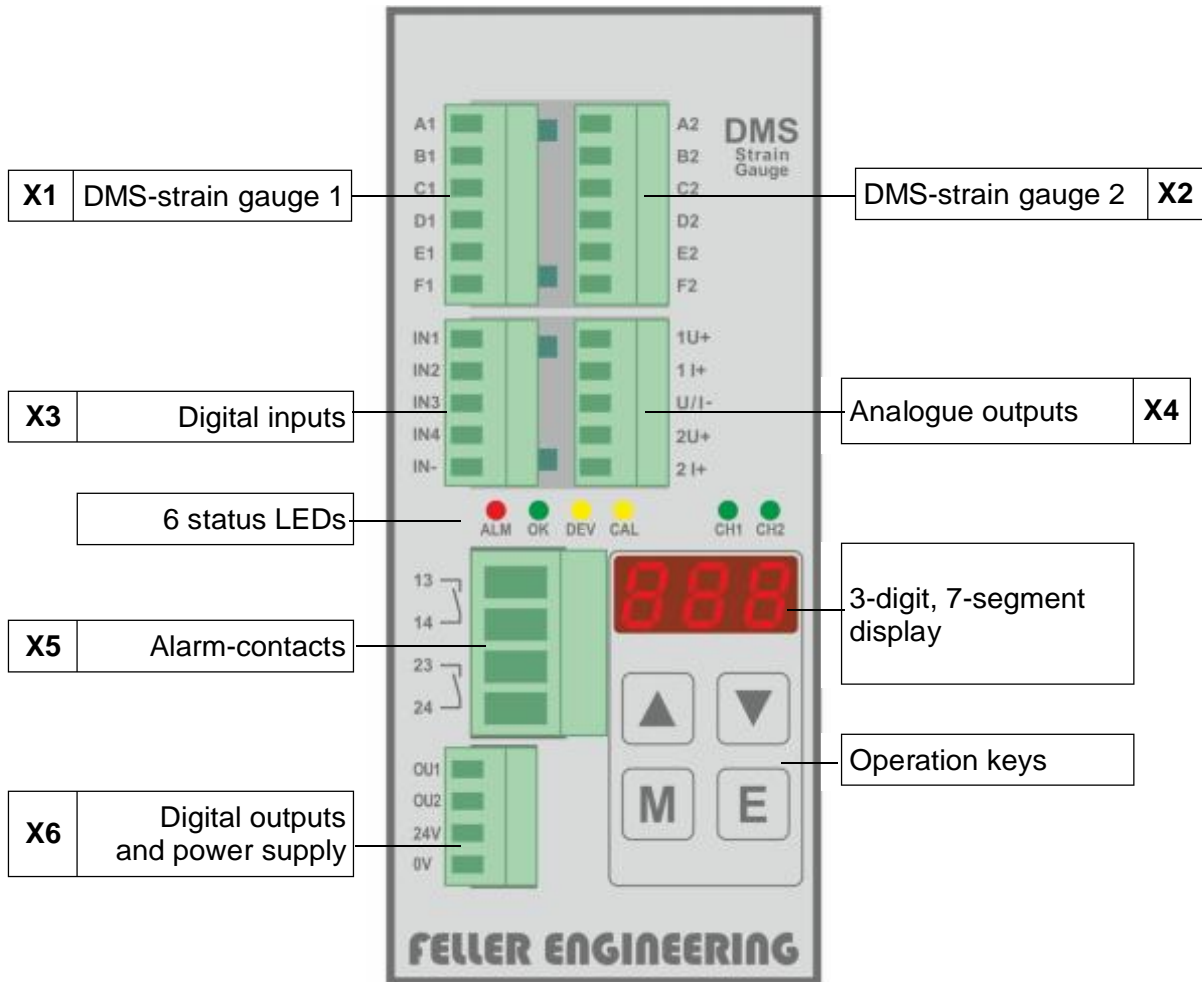

The terminal connectors are designed for wiring with end splices.

5.1 Application of the terminal strips

Terminal strip	Application	Capacity	Cross section
X1	DMS-strain gauge 1	10 VDC	1,5 mm ²
X2	DMS-strain gauge 2	10 VDC	1,5 mm ²
X3	Digital inputs	24 VDC	1,5 mm ²
X4	Analogue outputs	10 VDC / 20 mA	1,5 mm ²
X5	Alarm contacts (dry relays)	250 VAC / 2 A	2,5 mm ²
X6	Digital outputs & supply	24 VDC	1,5 mm ²

5.2 Types of Connections

5.2.1 General Hints for the coded plugs

Each one of the described terminal connectors X1...X6 is pluggable and coded that way, which it matches only at one position of the unit.

Units of identical construction are identically coded. An exchange of the units is possible without newly wiring. The already wired connectors have just to be put to the new unit.

5.2.2 Realization of the Wiring

The connectors shall be unplugged for mounting and the referring wiring. There is no special tool required, a typical screw driver 0,4 x 2,5 x 80 mm may be used. The connectors catch with replacing and hold it.

5.2.2.1 X1: DMS-strain gauge 1

The terminal contact X1 is a 6-pin plug for the connection of a standard DMS strain gauge.

X1.A1	+ strain gauge signal
X1.B1	- strain gauge signal
X1.C1	+ supply for the gauge
X1.D1	- supply for the gauge
X1.E1	contact 80 % load
X1.F1	contact 80 % load

5.2.2.2 X2: DMS-strain gauge 2

The terminal contact X2 is identical to X1.

X2.A2	+ strain gauge signal
X2.B2	- strain gauge signal
X2.C2	+ supply for the gauge
X2.D2	- supply for the gauge
X2.E2	contact 80 % load
X2.F2	contact 80 % load



There might be connected only identical types of DMS strain gauges!

5.2.2.3 X3: Digital Inputs

The digital inputs are provided for operation from the control level. The control takes place via 24 VDC.

X3.IN1	Activation of the calibration routine
X3.IN2	without function
X3.IN3	Acknowledge of alarms
X3.IN4	Switch the analogue output to the value of calibration
X3.IN-	Common potential for all digital inputs.

It is definitely required to wire this terminal.

5.2.2.4 X4: Analogue Outputs

X4.1 U+	1. voltage output 0..5 VDC or 0..10 VDC
X4.1 I+	1. voltage output 0..5 VDC or 4..20 mA
X4.U/I-	Common potential for all analogue outputs it is definitely required to wire this terminal.
X4.2 U+	2. voltage output 0..5 VDC or 0..10 VDC
X4.2 I+	2. voltage output 0..5 VDC or 4..20 mA

5.2.2.5 X5: Alarm Contacts

X5.13	1. dry contact (fail safe) by relay
X5.14	max. load 250 VAC / 2 A or 24 VDC
X5.23	2. dry contact (fail safe) by relay
X5.24	max. load 250 VAC / 2 A or 24 VDC



The two dry contacts are galvanic isolated and may be used with different control voltage.



The alarm contacts are designed for primary ohmic load. With the referring RC-filters relays may be connected as well. The switched circuits must be protected by external fuse!

5.2.2.6 X6: Digital Outputs

X6.OU1	1. Digital output 24 VDC / max. 12 mA
X6.OU2	2. Digital output 24 VDC / max. 12 mA

Valid for both outputs: In case of failure 0V, healthy 24V



The reference potential for the digital outputs is X6: 0V.



The digital outputs are designed for a high-resistance load of 24 VDC at the control level. It is not allowed to switch any load!

5.2.2.7 X6: Power supply

- X6. 24V Supply 24 VDC (5W; 18VDC – 32 VDC)
- X6. 0V Supply ground (internally not connected to X3:IN- or X4:U/I-)



The power supply of 24 VDC must be protected by external fuse.

5.3 Status LEDs

- ALM Lights RED, if an alarm occurs (HI-alarm, WD-alarm, Sensor fault, internal hardware fault)
- OK Lights GREEN, if the unit is in correct conditions, healthy
- DEV Lights YELLOW, if a deviation failure occurs
- CAL Lights YELLOW during calibration
- CH1, CH2 Light GREEN, while the 7-segment display indicates actual values

5.4 7-Segment Display

The 7-segment display indicates values, status-information or parameters.



Three digits 7-segment display

The 7-segment display may even indicate decimal points and a selection of symbols besides the numbers.

Indicated feature	Indication	Example
Name of parameters	3 symbols	HYS
Value of parameters while indication	Up to 3 numbers, max. 1 decimal dot	12.3
Value of parameters while changes	Up to 3 numbers always with 3 decimal dots	0.1.0.
Indication of failures	1 symbol with decimal dot und 1 number	E. 1

5.5 Operation Keys



UP

Menu control: One item up
Value setting: Increase value for 1 digit



DOWN

Menu control: One item down
Value setting: Decrease value for 1 digit



MODE

Change the display for the pressure value



ENTER

Start / finish the Enter-mode

6 Operation of **AT267**

6.1 Power the Module

After powering the module, the display will indicate for a few seconds the name of the module (e.g. **AT.267**) followed by the number of the version (e.g. **UEF-100**).

6.2 Indication of the Measured Value

The default indication in the three digit display is the sum of both measured values. This is signed by the two green LEDs CH1 and CH2. By the key **M** one of the values may be indicated separately. The referring status LED CH1 or CH2 indicates the reference of the value.

6.4 Indication of Parameter Values

The arrow keys **▲** **▼** select one of the parameters as described in chapter 6.8. The display indicates the name of the parameter e.g. **dF**. The release of the key starts toggling the display with the actual setting and the name of the parameter e.g. (**dF** and the setting „**10**“).

6.5 Change Parameters

The **E** key starts the change of the selected parameter. The module provides an interlock via passcode. That is why the passcode maybe required at first:

6.5.1 Unlock

At the beginning **LOC** flashes. The passcode (e.g. 22) has to be entered by the keys **▲** **▼** and must be confirmed by the key **E**. A wrong code will inhibit parameter settings. The successful unlock opens the enter mode, which is indicated by 3 flashing decimal dots with the name of the parameter (e.g. **d..F**). The unit will be unlocked for 120 seconds and needs no further code for settings. Each activation of any key restarts the time of 120 seconds. After a rest of 120 seconds the unit locks itself.

6.5.2 Setting Values

The arrow keys enable the selection of the desired parameter. As long as the key is kept pressed, there is just the setting in the display. After the release of the key, the name of the parameter toggles with the value. The key **E** confirms the preset value, the flashing of the three decimal dots stops und the value is valid.

Settings out of the allowed range are not possible. Parameters which are marked “read only” cannot be changed. Longer pressing of the key speeds the change of the setting. If no key will be pressed for 10 minutes, the display returns to the default indication. The key **M** may cancel the setting without confirmation.

6.6 Acknowledgement of failures

The operator has to acknowledge appearing failures or alarms. This may be done locally by the key **[E]** alternatively via activation of the digital input OU3 > 100ms. The failure will be upheld till to the acknowledgement:

- * Alarm contact OPEN,
- * Analogue output value of overflow,
- * Digital output 0V,
- * Failure indication in the display referring to table 6.10

6.7 Reset to default Settings

The module may be reset to the default settings. All individual settings and the calibration get lost. To return to these base settings the keys **[M]** and **[▼]** have to be pressed for 10 seconds. While this procedure there appears a countdown. A release of the keys within this time will break the reset. After 10 seconds the module returns to the base settings of the status of delivery.

6.8 Parameter List

Indication	Signification
<i>Lo</i>	Lower limit, relative to <i>Ab5</i>
<i>Hi1</i>	Upper limit 1 relative to <i>Ab5</i>
<i>Hi2</i>	Upper limit 2 relative to <i>Ab5</i>
<i>dF</i>	Maximum difference
<i>Uou</i>	Config. analogue output U+
<i>Iou</i>	Config. analogue output I+
<i>dLY</i>	Delay
<i>An2</i>	Function of the 2 nd analogue output
<i>Pin</i>	max. negative pressure value
<i>rEF</i>	Upper calibration value
<i>HYS</i>	Hysteresis of alarm
<i>Ab5</i>	Maximum indication value
<i>Id</i>	Code input
<i>O-1</i>	Offset DMS-strain gauge1
<i>E-1</i>	Gain of DMS-strain gauge1
<i>S-1</i>	Sensitivity DMS-strain gauge1
<i>O-2</i>	Offset DMS-strain gauge2
<i>E-2</i>	Gain of DMS-strain gauge2
<i>S-2</i>	Sensitivity DMS-strain gauge2
<i>CF6</i>	Configuration of hardware
<i>UEr</i>	Software version of the unit

6.9 Detailed Description of the Parameters

Lo		Lower limit, relative to <i>Rb5</i>
Min	0	Lo-alarm will be activated, if the sum of both measured values decrease to this setting. Example: <i>Rb5</i> = 350, <i>Lo</i> = 10 → alarm will be activated below 10% of 350, means < 35. LO-alarm: * turns the digital output OU2 remaining off. * opens contacts 13-14 as well as 23-24 * puts the overflow value to the analogue outputs (11V or 24mA) * indicates failure code E.7 and E.8 in the display. The alarm has to be acknowledged either via the digital input QUIT (IN3) or manually by the key E . The setting <i>Lo</i> = 0 disables the supervision of Lo-alarm.
Max	The lowest setting of <i>Hi</i> or <i>H2</i> - 1	
Default	0	
Unit	%	
Hi		Upper limit 1, relative to <i>Rb5</i>
Min	<i>Lo</i> + 1	Hi-alarm will be activated, if the sum of both measured values increase to this setting. Example: <i>Rb5</i> = 350, <i>Hi</i> = 90 → → alarm will be activated above 90% of 350, means > 315. HI-alarm: * turns the digital output OU2 remaining off. * opens contacts 13-14 as well as 23-24 * puts the overflow value to the analogue outputs (11V or 24mA) * indicates failure code E.5 and E.6 in the display. The alarm has to be acknowledged either via the digital input QUIT (IN3) or manually by the key E . <i>H2</i> will automatically take over this setting.
Max	107	
Default	90	
Unit	%	

<i>H₂</i>		Upper limit 2, relative to <i>R_{b5}</i>
Min	<i>L₀</i> + 1	<p>Hi-alarm will be activated, if the sum of both measured values increase to this setting.</p> <p>Example: <i>R_{b5}</i> = 350, <i>H₂</i> = 90 → → alarm will be activated above 90% of 350, means > 315.</p> <p>HI-alarm:</p> <ul style="list-style-type: none"> * turns the digital output OU2 remaining off. * opens contacts 13-14 as well as 23-24 * puts the overflow value to the analogue outputs (11V or 24mA) * indicates failure code E.5 and E.6 in the display. <p>The alarm has to be acknowledged either via the digital input QUIT (IN3) or manually by the key E .</p> <p><i>H₁</i> will automatically take over this setting.</p>
Max	107	
Default	90	
Unit	%	

<i>dF</i>		Max. accepted difference between measured values 1 and 2
Min	0.0	<p>DIF-alarm will be activated, if the difference between the both measured values increases to this setting. The value can be set in steps of 0.1%. The adjustment of 0.0% deactivates this alarm.</p> <p>Example: <i>R_{b5}</i> = 350, <i>dF</i> = 20.0 → alarm will be activated, if the difference of both signals is > 70.</p> <p>DIF-alarm:</p> <ul style="list-style-type: none"> * turns the digital output OU1 remaining off. * opens contacts 13-14 as well as 23-24 * puts the overflow value to the analogue outputs (11V or 24mA) * indicates failure code E.9 in the display. <p>The alarm has to be acknowledged either via the digital input QUIT (IN3) or manually by the key E .</p>
Max	100	
Default	25.0	
Unit	%	

<i>U_{ou}</i>		Range of output voltage
Min	0	<p>This parameter selects the type of analogue output voltage signal at the terminals 1U+ and 2U+:</p> <p>0 = output disabled</p> <p>1 = output 0..5V</p> <p>2 = output 0..10V</p>
Max	2	
Default	0	
Unit	-	

<i>iou</i>		Range of output current
Min	0	This parameter selects the type of analogue output current signal at the terminals 1I+ and 2I+: 0 = output disabled 1 = output 0..20 mA 2 = output 4..20 mA 3 = output 0..24 mA (ref. to Namur NE43) If <i>iou</i> was set to 3, <i>Uou</i> will be automatically 0.
Max	3	
Default	2	
Unit	-	

<i>dLY</i>		Alarm delay
Min	0	An alarm will just be generated, if it lasts continuously longer than the time (in seconds) set here. The setting of 0 enables a direct alarm without delay.
Max	20	
Default	0	
Unit	sec	

<i>An2</i>		Function of the 2nd alarm output
Min	0	0 = The output will put the measured value of sensor 2. 1 = The output will put the sum of the measured values of sensors 1 and 2. 2 = The output will put the difference of the measured values of sensors 1 and 2.
Max	2	
Default	0	
Unit	-	

<i>nin</i>		Lowest accepted negative measured value
Min	0.0	A negative measured value should not decrease to a deviation from the final value by the % set here. Otherwise the MIN-alarm will be set. The value can be set in steps of 0.1%. The adjustment of 0.0% deactivates this alarm. MIN-alarm: * opens contacts 13-14 as well as 23-24 * puts the overflow value to the analogue outputs (11V or 24mA) * indicates failure code E.3 and E.4 in the display.
Max	100	
Default	0.0	
Unit	%	

<i>rEF</i>		Upper calibration value
Min	10	The upper reference of the calibration routine refers to this value (see → calibration). Changes of the <i>rEF</i> value after calibration process have no influence on the operation, as long as the module is not recalibrated. Example: <i>RbS</i> = 350, <i>rEF</i> = 50 → The reference for calibration is 175.
Max	100	
Default	100	
Unit	%	

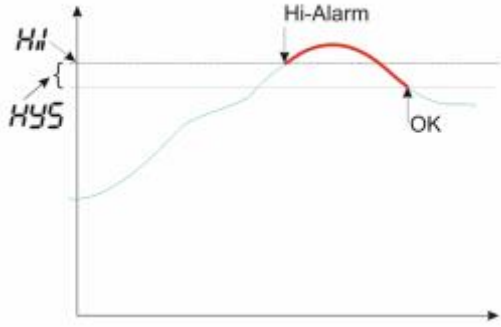
HYS		Alarm hysteresis relative to <i>Ab5</i>
Min	0.0	<p>Overriding the Hi-value creates an alarm. This might be to acknowledge only, if the measured value decreases for this rate below the Hi-value. The value can be set in steps of 0.1%.</p> 
Max	20.0	
Default	5.0	
Unit	%	

Ab5		Maximum value for indication
Min	10	<p>The maximum value for indication <i>Ab5</i> defines the upper measured value, which will be indicated in the display. <i>Ab5</i> should be set before starting the calibration routine.</p> <p>The value has to correspond to the technical data of the wired sensors. <u>Meaningfully for AT267, the sum of the two nominal measuring forces of the individual sensors should be entered here.</u></p> <p>Not binding examples: 350 for 350bar; 100 for 100kg; 500 for 5000N (500, as the display only represents a maximum of 3 digits → factor 10 smaller);...</p> <p>If the measured signal reaches the maximum value for indication <i>Ab5</i>, the max. voltage will be put to the output.</p> <p>Changes of the <i>Ab5</i> value after calibration only affect the display of the AT267. Dependent relative values, such as the switching point of the upper limit values, remain independent of a change as long as the module is not recalibrated.</p>
Max	999	
Default	100	
Unit	-	

id		Password
Min	0	<p>The required password for changes will be defined here. The value of <i>id</i> is only visible after activation with the actual password.</p>
Max	999	
Default	22	
Unit	-	

O-1		Offset sensor 1
Min	Read only	<p>The calibrated offset for sensor 1 may be read-out here.</p>
Max	Read only	
Default	-	
Unit	%	

E-1		Gain sensor 1
Min	Read only	The calibrated gain for sensor 1 may be read-out here.
Max	Read only	
Default	-	
Unit	‰ / digit	

S-1		Sensitivity sensor 1
Min	Read only	The calibrated sensitivity for sensor 1 may be read-out here.
Max	Read only	
Default	-	
Unit	mV / 10V	

O-2		Offset sensor 2
Min	Read only	The calibrated offset for sensor 2 may be read-out here.
Max	Read only	
Default	-	
Unit	%	

E-2		Gain sensor 2
Min	Read only	The calibrated gain for sensor 2 may be read-out here.
Max	Read only	
Default	-	
Unit	‰ / digit	

S-2		Sensitivity sensor 2
Min	Read only	The calibrated sensitivity for sensor 2 may be read-out here.
Max	Read only	
Default	-	
Unit	mV / 10V	

CF6		Module type
Min	Read only	The type of module may be read-out here (265, 266 or 267).
Max	Read only	

UEr		Software version
Min	Read only	The version of the software may be read-out here.
Max	Read only	

7 Failure codes

7.1 Failure codes in the display

The following failure codes are displayed in case of an error. Simultaneous these codes also cause the opening of relay contacts 13-14 and 23-24 as well as the deactivation of digital output OU2.

Failure codes of the sensors			
Indication	Signification	Reason	Remedy
E.1	Broken sensor, shorted sensor, wrong wiring for DMS-strain gauge1	A failure in the connection of DMS-strain gauge1 was detected. The reason might be an interrupted connection, a wrong wiring or a defective DMS-strain gauge.	Check the DMS-strain gauge1 and the wired connection to the module.
E.2	Broken sensor, shorted sensor, wrong wiring for DMS-strain gauge2	A failure in the connection of DMS-strain gauge2 was detected. The reason might be an interrupted connection, a wrong wiring or a defective DMS-strain gauge.	Check the DMS-strain gauge2 and the wired connection to the module.
E.3	Drop below negative limit n_{in} of DMS-strain gauge1	The pressure load takes place in reverse direction. The negative input voltage at the connection of DMS-strain gauge1 dropped below the limit.	Pass the calibration without pressure load. If there is no success, check the installation of DMS-strain gauge1.
E.4	Drop below negative limit n_{in} of DMS-strain gauge 2	The pressure load takes place in reverse direction. The negative input voltage at the connection of DMS-strain gauge2 dropped below the limit.	Pass the calibration without pressure load. If there is no success, check the installation of DMS-strain gauge2.
E.5	Exceeded max. limit H_i of DMS-strain gauge1	The pressure value is higher than the defined max. value for DMS-strain gauge1, the alarm contact opens.	Adjust the upper limit, if the alarm appears too often.

E.6	Exceeded max. limit Hi of DMS-strain gauge2	The pressure value is higher than the defined max. value for DMS-strain gauge2.	Adjust the upper limit, if the alarm appears too often.
E.7	Lo -alarm of DMS-strain gauge1 or DMS-strain gauge2	One the measured values of DMS-strain gauge1 or DMS-strain gauge2 are lower than the accepted Lo-value.	Investigate the reason for the low value. The basic load might be missing. Adjust the Lo-value, if the alarm appears too often.
E.8	./.		
E.9	dF -warning of DMS-strain gauge1 (exceeded difference)	The difference between DMS-strain gauge1 and DMS-strain gauge2 is greater than the accepted max. value for the difference.	Investigate the reason for the difference of pressure. Adjust the value for the difference, if the alarm appears too often.

Failure codes of the hardware

Indication	Signification	Reason	Action
E.17	Voltage supply out of accepted tolerance	Failure of hardware	Send the module for check.
E.18	Defective source for reference voltage	Failure of hardware	Send the module for check.
E.19	Sensor supervision of DMS-strain gauge1 defective	Failure of hardware or short circuit at the sensor input	Send the module for check.
E.20	Sensor supervision of DMS-strain gauge2 defective	Failure of hardware or short circuit at the sensor input	Send the module for check.
E.21	Supply voltage for analogue outputs Uout/Iout defective	Failure of hardware	Send the module for check.
E.22	Parameter memory for the configuration defective	Failure of hardware	Send the module for check.
E.23	AD-converter for channel 1 defective	Failure of hardware	Send the module for check.
E.24	AD-converter for channel 2 defective	Failure of hardware	Send the module for check.
E.25	Retrieval of the digital inputs and retrieval of the operation keys defective	Failure of hardware	Send the module for check.
E.26	External hardware supervision (Watchdog) fails	Failure of hardware	Send the module for check.

E.27	Signal failure at analog output 1	Connection of analog output between module and machine control is interrupted.	Check the external wiring of the outputs Uout and lout: Load for lout greater than 500 Ohm? Wiring between lout and the machine broken? Shorted circuit at Uout? If analogue output 1 is not used, terminals 1I+ and U/I- should be bridged to avoid the error.
E.28	Signal failure at analog output 2	Connection of analog output between module and machine control is interrupted.	Check the external wiring of the outputs Uout and lout: Load for lout greater than 500 Ohm? Wiring between lout and the machine broken? Shorted circuit at Uout? If analogue output 2 is not used, terminals 2I+ and U/I- should be bridged to avoid the error.

Failure codes of the calibration

Indication	Signification	Reason	Remedy
E.29	Calibration failure: DMS1 upper reference not detected.	No signal or too low signal from sensor DMS1 when calibrating the (upper) reference value.	Repeat calibration; check the sensor and its installation position, if necessary
E.30	Calibration failure: DMS2 upper reference value not detected.	Like E.29, but for DMS2	Like E.29, but for DMS2
E.31	Calibration failure: DMS1 amplification	Too high signal from sensor DMS1 when calibrating the (upper) reference value.	Repeat calibration; check the sensor and its installation position, if necessary
E.32	Calibration failure: DMS2 amplification	Like E.31, but for DMS2	Like E.31, but for DMS2

7.2 Warning messages

In the event of a warning, the following warning messages can be displayed which cause the digital output OU1 to be switched off. In contrast to error messages, warnings don't need be acknowledged.

Warning messages			
Indication	Signification	Reason	Action
<i>H!</i>	Not used in module AT267		

7.3 Behavior of the outputs in case of an error

Output	Cause of failure	Behavior
Analog output 1	<ul style="list-style-type: none"> • DMS1+DMS2 < lower limit Lo or • DMS1+DMS2 > upper limit Hi or • DMS1 or DMS2 < lowest permitted, negative measured value Pin or • Difference DMS1 to DMS2 > maximum permitted difference dF • DMS1 or DMS2 sensor brake, short circuit, wrong wiring 	Overflow value (11V or 24mA) until confirmation
Analog output 2	<ul style="list-style-type: none"> • Identical to analog output 1 	
Relay output 1 (terminal 13-14)	<ul style="list-style-type: none"> • DMS1+DMS2 < lower limit Lo or • DMS1+DMS2 > upper limit Hi or • Difference DMS1 to DMS2 > maximum permitted difference dF or • DMS1 or DMS2 sensor brake, short circuit, wrong wiring or • During calibration • Hardware error 	Contact opens until confirmation
Relay output 2 (terminal 23-24)	<ul style="list-style-type: none"> • Identical to relay output 1 	Contact opens until confirmation
24V output OU1	<ul style="list-style-type: none"> • Difference DMS1 to DMS2 > maximum permitted difference dF 	Switch off until confirmation
24V output OU2	<ul style="list-style-type: none"> • DMS1+DMS2 < lower limit Lo or • DMS1+DMS2 > upper limit Hi or • DMS1+DMS2 > upper limit Hi2 or • DMS1 or DMS2 sensor brake, short circuit, wrong wiring 	Switch off until confirmation

8 Commissioning and Configuration

8.1 Calibration of DMS-Strain Gauge

The amplifier module has to be calibrated to the DMS-strain gauges to respect their electrical features. Independent of this, a new calibration for a start-or offset value may be required after heating or restraining. The module is checked and preset by the maker. An individual adjustment to the DMS-strain gauges happens with the commissioning and may be changed at any time.

8.1.1 Appropriate DMS-Strain Gauges

The module is designed for the use with DMS-strain gauges, which are built referring to the following scheme:

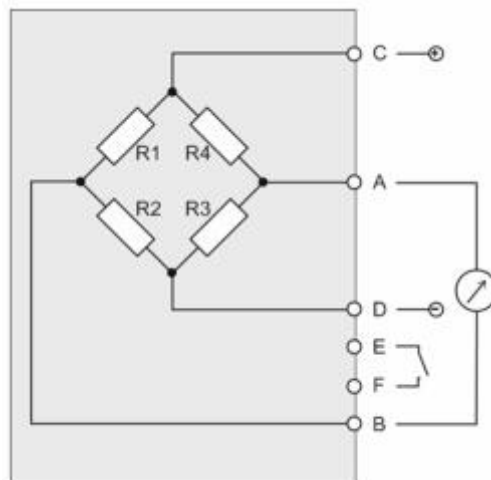

Equivalent circuit diagram of the DMS-strain gauge pressure transducer (Wheatstone-Bridge)

Suitable pressure transducer have to fulfil the following technical Data:

Full bridge resistance:	$\geq 350 \Omega$
Maximum signal level:	0,1mV/V...10mV/V

:

8.2 Calibration Routine

To keep influences by temperature at a low level, the calibration should take place under usual operation temperature only 10 minutes after powering the module as well as the DMS-strain gauge.

Before starting the calibration there are meaningful settings for the DMS-strain gauge by parameter **AbS** and **rEF** required. During calibration the relay contacts 13-14 and 23-24 are open (alarm status). The calibration routine may be started via operation keys or by the input IN1.

8.2.1 Start of the Calibration Routine by the Digital Input

- 1.) The strain gauges must be unloaded for the zero set.
- 2.) Power the digital input IN1 at 24V and keep it. The display indicates **CAL** with a running decimal dot.
- 3.) Load the strain gauges symmetrically with a previously defined load, by parameter **rEF**.
- 4.) Turn off the 24V power from digital input IN1.
- 5.) The module is calibrated.

An active calibration routine may be cancelled by the key **M**.

8.2.2 Start of the Calibration Routine via Operation Keys

- 1.) The strain gauges must be unloaded for the zero set.
- 2.) Press the keys **E** and **M** together for 5 seconds. A countdown 5...0 will be indicated followed by **CAL** with a running decimal dot.
- 3.) Release the keys.
- 4.) Load the strain gauges symmetrically with a previously defined load, by parameter **rEF**.
- 5.) Press key **E**.
- 6.) The module is calibrated.

An active calibration routine may be cancelled by the key **M**.

8.2.3 Important note after calibration



Immediately after the calibration procedure the measuring bridges are still loaded with the load necessary for the calibration. If this load has a higher value as the permissible maximum value set under *Hi* failure E.5 and/or E.6 are triggered. **DiesThis is a normal condition!** The measuring bridges have to be unloaded and the failure needs to be confirmed.

8.2.4 Indication of the Calibration Results

The characteristic values for gain and offset are available via operation menu (parameters *0-1 0-2 E-1 E-2 S-1 S-2*).

9 Appendix

9.1 Definition „NAMUR NE43“

The signal 4...20 mA is widely used in the transmission of sensor values. In a production processes for example a measured pressure 0...10 bar will be converted to an electric signal of 4...20 mA by a pressure transducer.

To indicate a recognize sensor damage with the current loop, the module delivers a current value of > 21 mA according to NAMUR recommendation NE43. In the range between 20 and 21 mA as well as between 3.6 and 4 mA, slight overshooting and undershooting can be detected.

The NAMUR characteristic can be activated by setting parameter **lou** to value 3. A simultaneous output of an 0...10 V signal isn't possible with this setting.

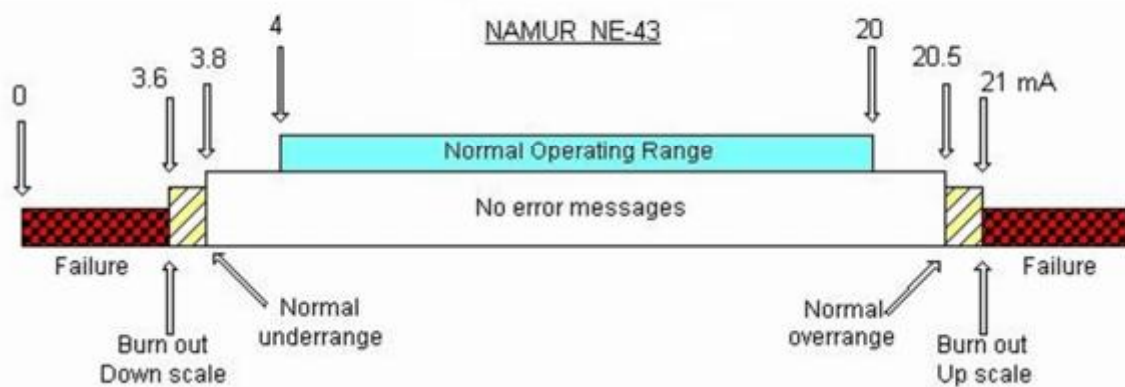

9.2 Optional accessories

9.2.1 Mounting bracket with shield clamps and PE connection

For optimal installation of the cable feed a mounting bracket with shield clamps and PE connection is available under order number 99-00162. This part ensures either a safe strain relief of the connection cable and furthermore a reliable grounding of the shield will be guaranteed.

The mounting bracket is pre-assembled and can be mounted on the amplifier module easily. The retrofit kit includes 2 screws for the attachment in 2 threaded holes which are already intended in the housing of the module.

As an alternative to the top mounting shown in the figure below, the bracket can also be mounted on the underside of the housing.

Using the mounting bracket increases the overall height of the module by 40 mm.



9.3 Technical Data

Housing and installation	
Dimensions (WxHxD)	53 mm x 116 mm x 125 mm
Weight	550 g
Material of the housing	metal
Protection category	IP 20
Mounting	Clip mechanism for mounting rail 35mm
Operation temperature	0..50°C / no dew drop
Operation Display Foil keys	3 x 7-segment 4
Digital inputs Digital input	
Analogue inputs DMS-strain gauge input	2 x 6-pin inputs (A1... F1 / A2...F2)
Electric connections	
Supply voltage Min...typical...Max	18VDC ... 24V DC ... 32V DC
Power consumption	max. 5 W
DMS-strain gauges	
Number of channels	2
Strain gauge supply	10 VDC stable / max 120 mA per sensor
Input sensitivity:	1mV/10V ... 100mV/10V
Offset/gain	Settings by calibration
Alarms	
	In case of overriding a max. value
Hysteresis of alarms	adjustable
Alarm relay, dry contact	2 x 250 VAC, 2 A
Digital alarm output	2 x 24 VDC, 12 mA
Delay	adjustable
Analogue outputs	
Voltage output	0...10 VDC or 0.5 VDC selectable
Current output	0...20 mA or 4...20 mA selectable or referring to Namur NE43 extended to 3,6...21 mA
Accuracy	
Temperature coefficient TK	max. 1,2 ppm FSR/°C (FSR = F ull S cale R ange)
Linearity error	max. 0,065 %FSR
Alerting	
Hysteresis alerting	Adjustable
Alarm relay, potential-free	2 x 250 VAC, 2 A
Digital-alarm output	2 x 24 VDC, 12 mA
Delay	Adjustable

FMEDA-characteristics*

Performance level	PL c
Hardware fail tolerance	HFT = 0
Structure Moon	1001
Proof Test Interval	T1(PL c) = 10 years
Mean time to failure MTTF _d per channel	
Digital OUT	1311 years
Analog OUT	843 years
Relay OUT	944 years
Useful life	10 years
PFH _d per Channel	
Digital OUT	87,1 FIT
Analog OUT	135,4 FIT
Relay OUT	120,9 FIT
PFD _{avg} (T1) per channel	
Digital OUT	$3,81 \times 10^{-3}$
Analog OUT	$5,93 \times 10^{-3}$
Relay OUT	$5,30 \times 10^{-3}$

*) Extract of FMEDA-data sheet of AT267 (can be requested separately)

Standards and Regulations

CE conformity:	EN 61326-1, EN 61000
EMC policy:	2014/30/EU
Low voltage policy:	2014/35/EU
RoHS:	2011/65/EU
Isolation test:	DIN EN 60204-1

9.4 Service Address

Regarding technical questions and in case of complaint please contact:

FELLER ENGINEERING GmbH
Carl-Zeiss-Str. 14
D-63322 Rödermark
Tel: +49 (0)6074 8949-0
Fax: +49 (0)6074 8949-49
www.fellereng.de

9.5 Customized parameters

Project: _____

Date: _____

Name: _____

Indication	Signification	Customer's setting
<i>Lo</i>	Lower limit, relative to <i>Ab5</i>	
<i>H1</i>	Upper limit 1 relative to <i>Ab5</i>	
<i>H2</i>	Upper limit 2 relative to <i>Ab5</i>	
<i>dF</i>	Max. value of difference	
<i>Uou</i>	Config. analogue output U+	
<i>Iou</i>	Config. analogue output I+	
<i>dLY</i>	Delay	
<i>An2</i>	Function of the 2 nd analogue output	
<i>P_{in}</i>	max. negative pressure value	
<i>rEF</i>	Upper calibration value	
<i>HYS</i>	Hysteresis of alarm	
<i>Ab5</i>	Maximum indication value	
<i>Id</i>	Code input	
<i>0-1</i>	Offset DMS-strain gauge1	
<i>E-1</i>	Gain of DMS-strain gauge1	
<i>S-1</i>	Sensitivity DMS-strain gauge1	
<i>0-2</i>	Offset DMS-strain gauge2	
<i>E-2</i>	Gain of DMS-strain gauge2	
<i>S-2</i>	Sensitivity DMS-strain gauge2	
<i>CFB</i>	Configuration of hardware	
<i>UEr</i>	Software version of the unit	

